

05.



TENDITORI WARDROBE ADJUSTERS

A vista | Visible P 186

Invisibili | Invisible P 206

Informazioni generali | General information P 247

SERIE TN100

TN100 SERIES

I tenditori della serie TN100 sono normalmente assemblati su pannelli di legno o agglomerati. Utilizzati anche su pannelli di tamburato.

CARATTERISTICHE FONDAMENTALI:

- Regolazione centrale.
- Lavorazioni simmetriche.
- Sistema di fissaggio con o senza viti.

Spessore minimo pannello 16, regolazione ± 10
interasse minimo 1200, interasse massimo 2800.

TN100 series tensioners are normally assembled on wooden panels or agglomerates. Also used on hollow wood panels.

KEY FEATURES:

- Central adjustment.
- Symmetric machining.
- Fixing system with or without screws.

Minimum panel thickness 16 adjustment ± 10 ,
minimum centre distance 1200, maximum centre distance 2800.

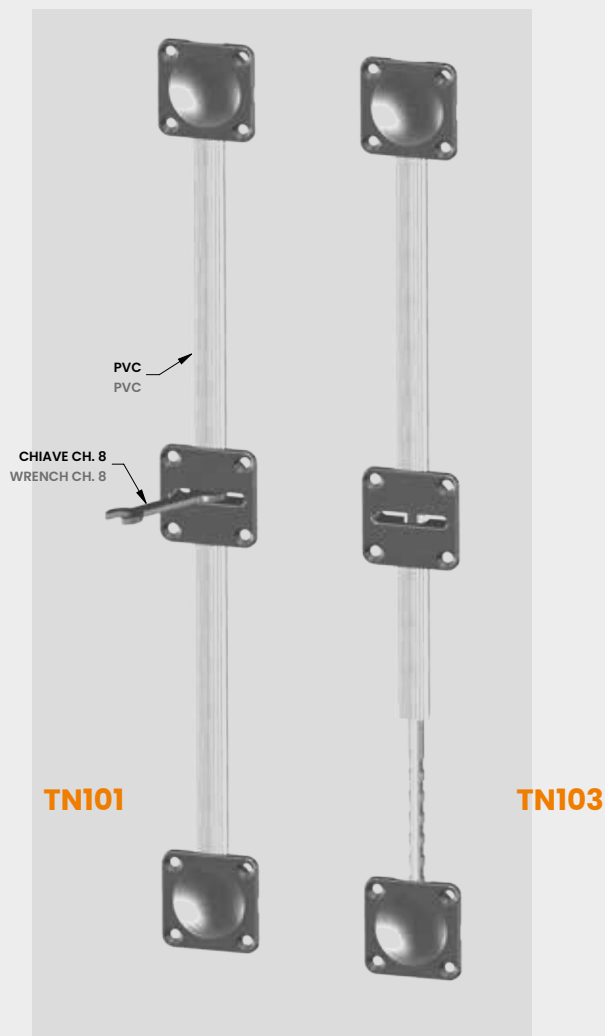

TN100

SCHEMA REGOLAZIONE TENDITORI

ADJUSTING SCHEME WARDROBE ADJUSTERS

Quando si assembla più di un tenditore sull'anta è importante tenere il riferimento della rotazione della chiave dallo stesso lato.

When assembling more than one tensioner on the door, it is important to keep the key rotation reference on the same side.

RIFERIMENTO PER ROTAZIONE CHIAVE
REFERENCE FOR THE ROTATION OF THE KEY

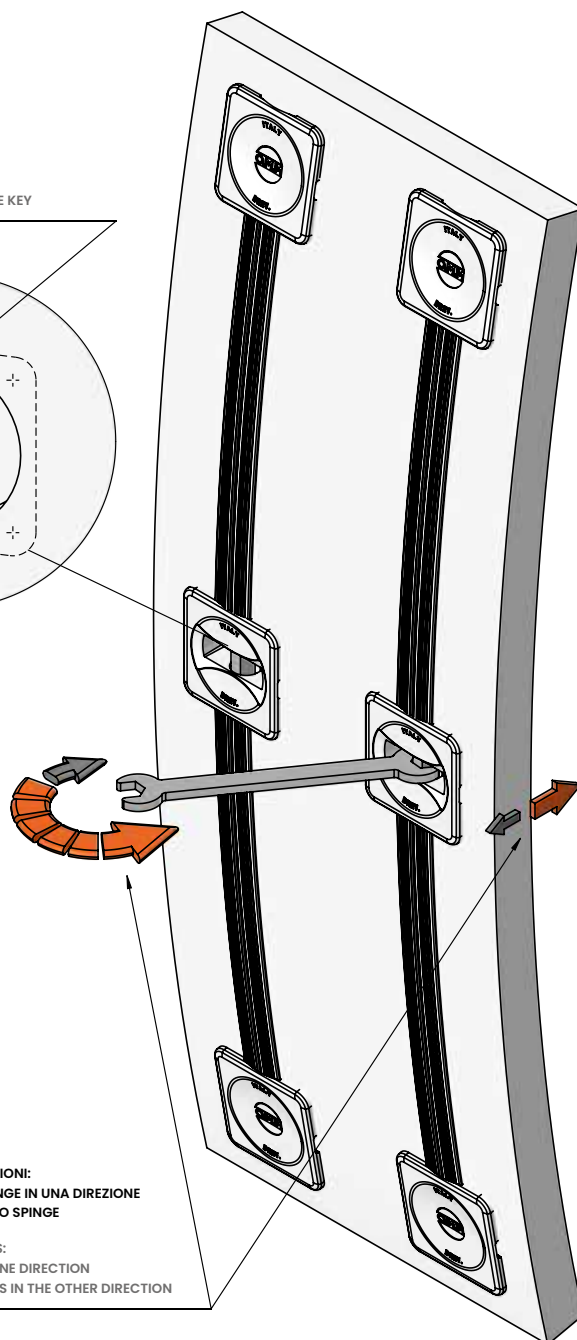
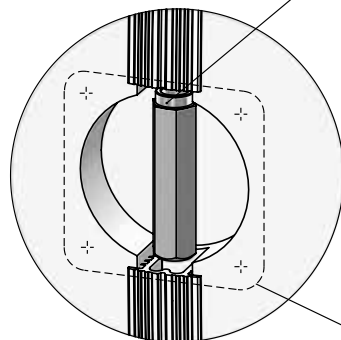

IL TENDITORE LAVORA IN ENTRAMBE LE DIREZIONI:
• GIRANDO LA CHIAVE IN SENSO ORARIO SPINGE IN UNA DIREZIONE
• GIRANDO LA CHIAVE IN SENSO ANTI-ORARIO SPINGE NELL'ALTRA DIREZIONE
THE TENSIONER WORKS IN BOTH DIRECTIONS:
• TURNING THE KEY CLOCKWISE PUSHES IN ONE DIRECTION
• TURNING THE KEY ANTI-CLOCKWISE PUSHES IN THE OTHER DIRECTION

TENDITORI - A vista
WARDROBE ADJUSTERS - Visible

TN101

TENDITORI DA INCASSO

RECESSED WARDROBE ADJUSTERS



- 1 PZ ASTA ACCIAIO TENDITORE 1 PCS ADJUSTER STEEL BAR
- 2 PZ BUSSOLE ZAMA ESTERNE 2 PCS EXTERNAL ZAMAK HOUSINGS
- 1 PZ BUSSOLA ZAMA CENTRALE 1 PCS INTERNAL ZAMAK HOUSING
- 2 PZ COPERTURE PVC 2 PCS PVC COVER

TOLLERANZA LUNGHEZZA COPERTURA PVC: L +3
 PVC COVER LENGTH TOLERANCE -1

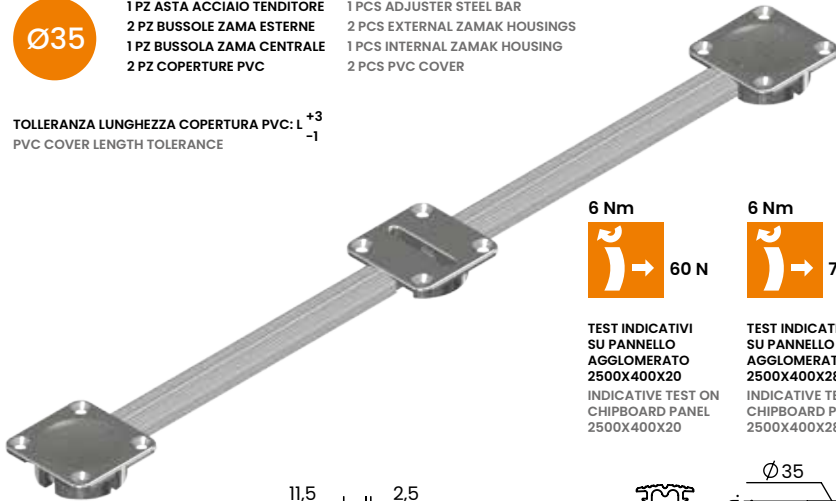

TEST INDICATIVI SU PANNELLO AGGLOMERATO 2500X400X20
 INDICATIVE TEST ON CHIPBOARD PANEL 2500X400X20



TEST INDICATIVI SU PANNELLO AGGLOMERATO 2500X400X28
 INDICATIVE TEST ON CHIPBOARD PANEL 2500X400X28

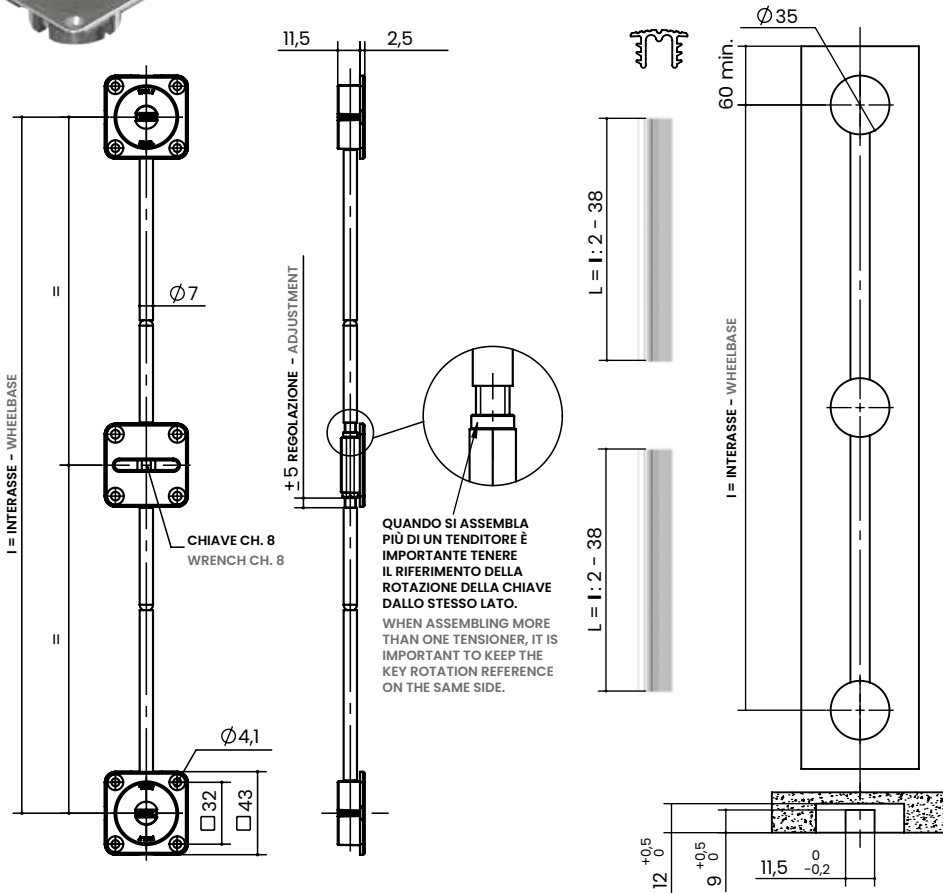

Normalmente assemblati su pannelli di legno o agglomerati e tamburati. Fissaggio con viti.

Spessore minimo 16.
 Interasse min. 1200, max. 2800.

PER MAGGIORI DETTAGLI TECNICI CONSULTARE 'INFORMAZIONI GENERALI' A FINE CAPITOLO 6.

Normally assembled on wooden panels or agglomerates and hollow wood panels. Fixing with screws.

Minimum thickness 16.
 Centre distance min. 1200, max. 2800.

FOR MORE TECHNICAL DETAILS, PLEASE REFER TO 'GENERAL INFORMATION' AT THE END OF SECTION 6.

ACCESSORI ACCESSORIES

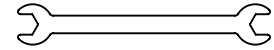

CHIAVE CH. 8
 WRENCH CH. 8
 P.A009.8

Per maggiori informazioni vedere sezione **10 ACCESSORI**

For further information see section **10 ACCESSORIES**

ULTERIORI COLORI PVC OTHER PVC COLORS

- RD** ARDESIA SLATE
- MTL** METALLIZZATO METAL GREY

TIPO TYPE	MISURA MEASURE	I INTERASSE WHEELBASE	FINITURA FINISHING	IMBALLO SU BANCALE PACKED ON PALLET KG / PZ	BOX 25 PZ KG / BOX	BOX 100 PZ KG / BOX
TN101.	1728.	1728	55 PVC GRIGIO GREY PVC	0,77	22	79
	1988.	1988	53 PVC NERO BLACK PVC	0,86	24	88
	2248.	2248	Minimo ordine 100 pz MOQ 100 pcs	0,96	25	98
	2330	2330	Misure a richiesta minimo ordine 300 pz Measure on request 300 pcs MO	0,98	26	100
	2600	2600		1,08	29	110

Codice composto con i dati evidenziati in arancione | Code composed with data highlighted in orange | es. e.g. **TN101.2248.55**

TN103

TENDITORI DA INCASSO TAGLIABILI CUTTABLE RECESSED WARDROBE ADJUSTERS



- 1 PZ ASTA ACCIAIO TENDITORE 1 PCS ADJUSTER STEEL BAR
- 2 PZ BUSSOLE ZAMA ESTERNE 2 PCS EXTERNAL ZAMAK HOUSINGS
- 1 PZ BUSSOLA ZAMA CENTRALE 1 PCS INTERNAL ZAMAK HOUSING
- 2 PZ COPERTURE PVC 2 PCS PVC COVER

TOLLERANZA LUNGHEZZA COPERTURA PVC: L +3
PVC COVER LENGTH TOLERANCE -1

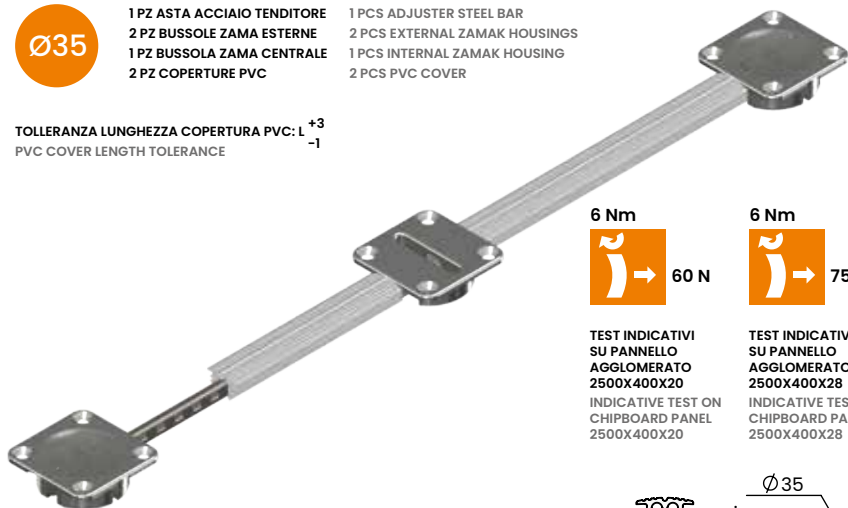

TEST INDICATIVI
SU PANNELLO
AGGLOMERATO
2500X400X20
INDICATIVE TEST ON
CHIPBOARD PANEL
2500X400X20



TEST INDICATIVI
SU PANNELLO
AGGLOMERATO
2500X400X28
INDICATIVE TEST ON
CHIPBOARD PANEL
2500X400X28

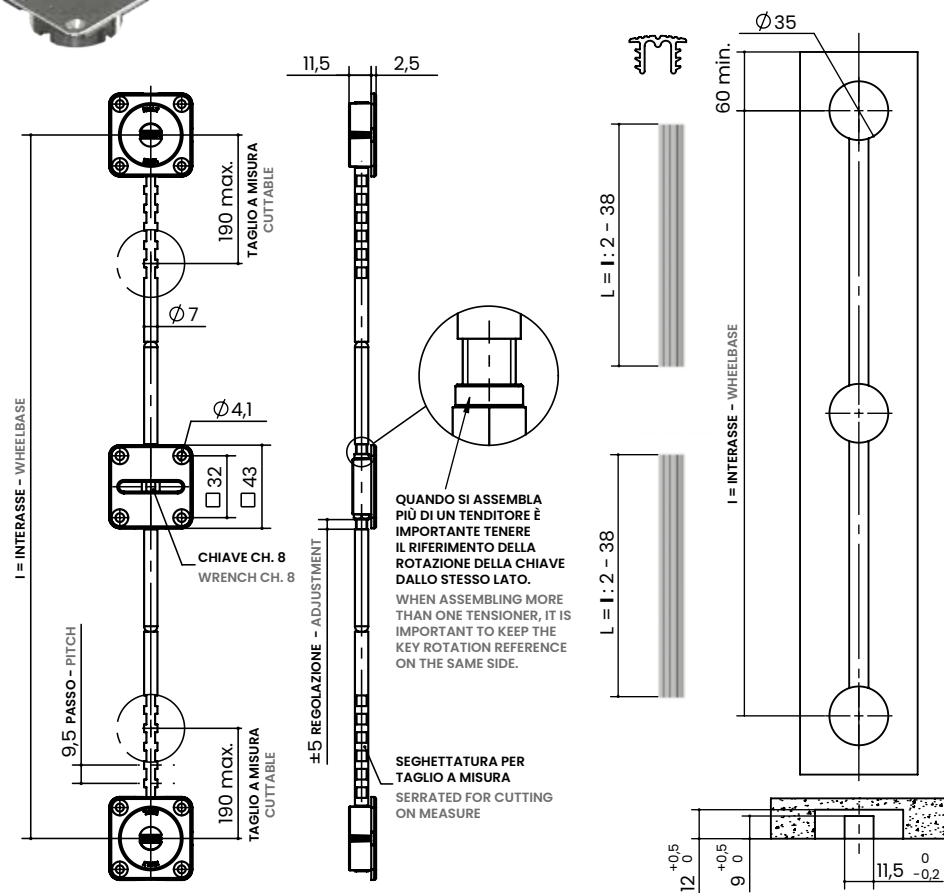

Normalmente assemblati su pannelli di legno o agglomerati e tamburati. Fissaggio con viti.

Spessore minimo 16. Interasse min. 1200, max. 2800.

PER MAGGIORI DETTAGLI TECNICI CONSULTARE 'INFORMAZIONI GENERALI' A FINE CAPITOLO 6.

Normally assembled on wooden panels or agglomerates and hollow wood panels. Fixing with screws.

Minimum thickness 16. Centre distance min. 1200, max. 2800.

FOR MORE TECHNICAL DETAILS, PLEASE REFER TO 'GENERAL INFORMATION' AT THE END OF SECTION 6.

ACCESSORI ACCESSORIES

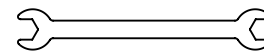

CHIAVE CH. 8
WRENCH CH. 8
P.A009.8

Per maggiori informazioni vedere sezione **10 ACCESSORI**

For further information see section **10 ACCESSORIES**

ULTERIORI COLORI PVC OTHER PVC COLORS

- RD ARDESIA SLATE
- MTL METALLIZZATO METAL GREY

TIPO TYPE	MISURA MEASURE	I INTERASSE WHEELBASE	FINITURA FINISHING	IMBALLO SU BANCALE PACKED ON PALLET KG / PZ	BOX 25 PZ KG / BOX	BOX 100 PZ KG / BOX
TN103.	1728.	1728	55 PVC GRIGIO GREY PVC	0,77	22	79
	1988.	1988	53 PVC NERO BLACK PVC	0,86	24	88
	2248.	2248	Minimo ordine 100 pz MOQ 100 pcs	0,96	25	98
	2330	2330	Misure a richiesta minimo ordine 300 pz Measure on request 300 pcs MO	0,98	26	100
	2600	2600		1,08	29	110

Codice composto con i dati evidenziati in arancione | Code composed with data highlighted in orange | es. e.g. TN103.2248.55

SERIE TN140

TN140 SERIES

Sono normalmente assemblati su pannelli di legno o agglomerati. Utilizzati anche su pannelli di tamburato.

CARATTERISTICHE FONDAMENTALI:

- Regolazione centrale.
- Lavorazioni simmetriche.
- Sistema di fissaggio con o senza viti.

Spessore minimo pannello 16, regolazione ± 10 , interasse minimo 1200, interasse massimo 2800.

TN140 series tensioners are normally assembled on wooden panels or agglomerates. Also used on hollow wood panels.

KEY FEATURES:

- Central adjustment.
- Symmetric machining.
- Fixing system with or without screws.

Minimum panel thickness 16, adjustment ± 10 , minimum centre distance 1200, maximum centre distance 2800.

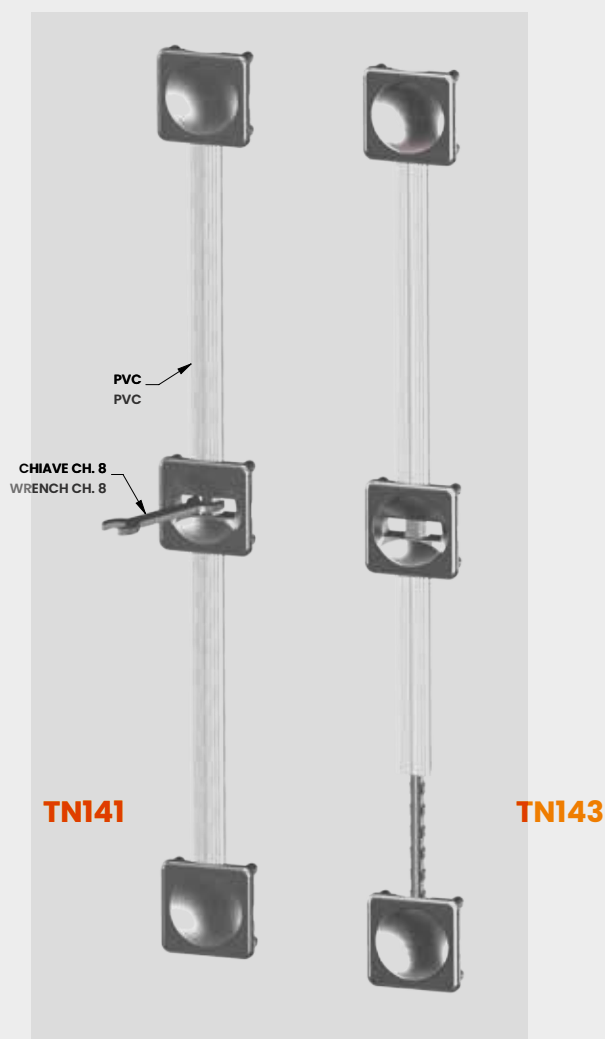

TN141

TENDITORI DA INCASSO

RECESSED WARDROBE ADJUSTERS

- Ø30**
- 1 PZ ASTA ACCIAIO TENDITORE 1 PCS ADJUSTER STEEL BAR
 - 2 PZ BUSSOLE ZAMA ESTERNE 2 PCS EXTERNAL ZAMAK HOUSINGS
 - 1 PZ BUSSOLA ZAMA CENTRALE 1 PCS INTERNAL ZAMAK HOUSING
 - 2 PZ COPERTURE PVC 2 PCS PVC COVER

TOLLERANZA LUNGHEZZA COPERTURA PVC: L +3
PVC COVER LENGTH TOLERANCE -1

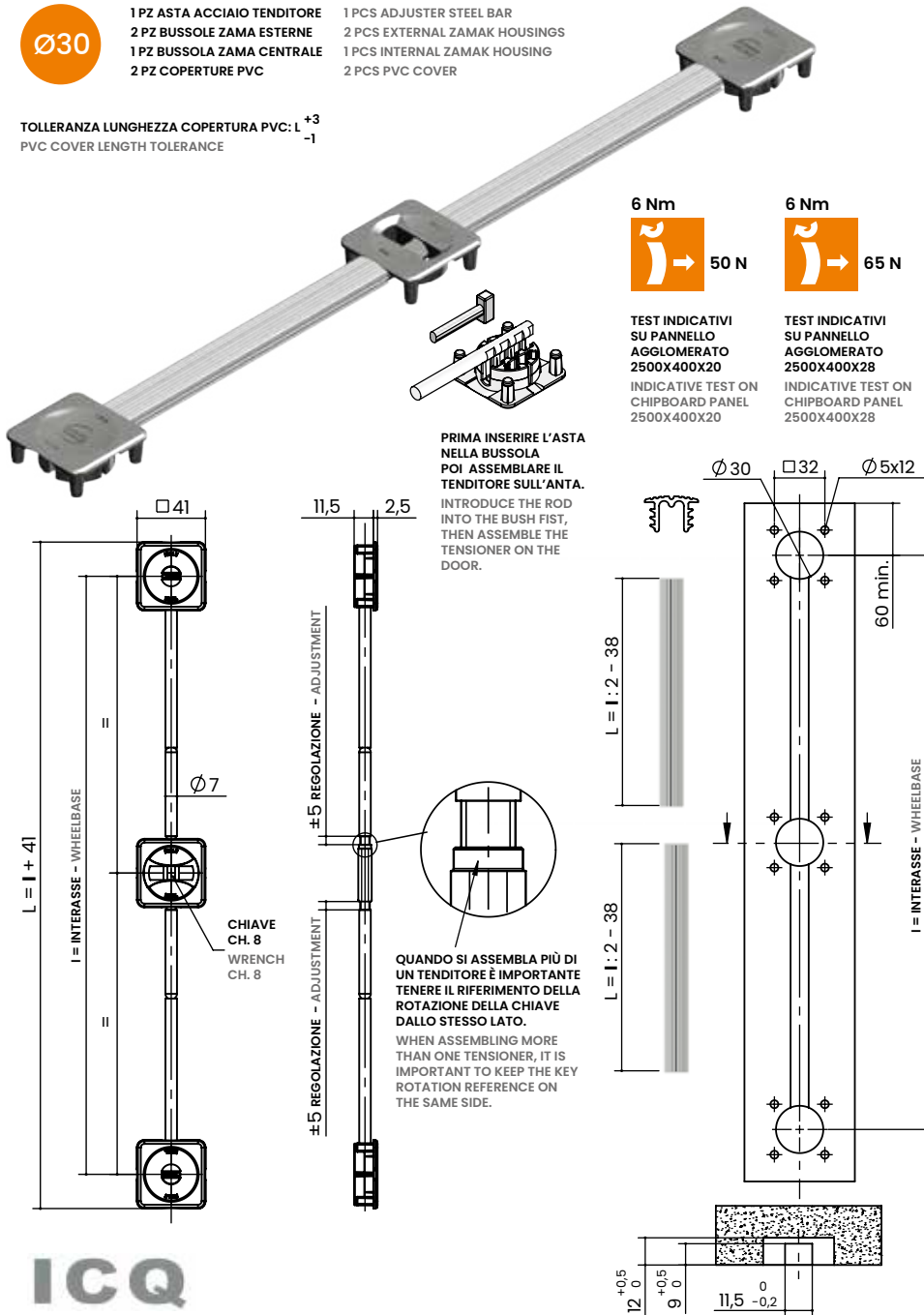

Normalmente assemblati su pannelli di legno o agglomerati e tamburati. Fissaggio senza viti.

Spessore minimo 16. Interasse min. 1200, max. 2800.

PER MAGGIORI DETTAGLI TECNICI CONSULTARE 'INFORMAZIONI GENERALI' A FINE CAPITOLO 6.

Normally assembled on wooden panels or agglomerates and hollow wood panels. Fixing without screws.

Minimum thickness 16. Centre distance min. 1200, max. 2800.

FOR MORE TECHNICAL DETAILS, PLEASE REFER TO 'GENERAL INFORMATION' AT THE END OF SECTION 6.

ACCESSORI ACCESSORIES

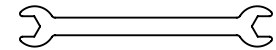

CHIAVE CH. 8
WRENCH CH. 8
P.A009.8

Per maggiori informazioni vedere sezione 10 ACCESSORI

For further information see section 10 ACCESSORIES

ULTERIORI COLORI PVC OTHER PVC COLORS

RD ARDESIA SLATE
MTL METALLIZZATO METAL GREY

ICQ
TEST REPORT 113710

TIPO TYPE	MISURA MEASURE	I INTERASSE WHEELBASE	FINITURA FINISHING	IMBALLO SU BANCALE PACKED ON PALLET KG / PZ	BOX 25 PZ KG / BOX	BOX 100 PZ KG / BOX
TN141.	1728.	1728	55 PVC GRIGIO GREY PVC	0,77	22	79
	1988.	1988	53 PVC NERO BLACK PVC	0,86	24	88
	2248.	2248	Minimo ordine 100 pz MOQ 100 pcs	0,96	25	98
	2330	2330	Misure a richiesta minimo ordine 300 pz Measure on request 300 pcs MO	0,98	26	100
	2600	2600		1,08	29	110

Codice composto con i dati evidenziati in arancione | Code composed with data highlighted in orange | es. e.g. TN141.2248.53

TN143

TENDITORI DA INCASSO TAGLIABILI CUTTABLE RECESSED WARDROBE ADJUSTERS



- 1 PZ ASTA ACCIAIO TENDITORE 1 PCS ADJUSTER STEEL BAR
- 2 PZ BUSSOLE ZAMA ESTERNE 2 PCS EXTERNAL ZAMAK HOUSINGS
- 1 PZ BUSSOLA ZAMA CENTRALE 1 PCS INTERNAL ZAMAK HOUSING
- 2 PZ COPERTURE PVC 2 PCS PVC COVER

TOLLERANZA LUNGHEZZA COPERTURA PVC: L +3
PVC COVER LENGTH TOLERANCE -1

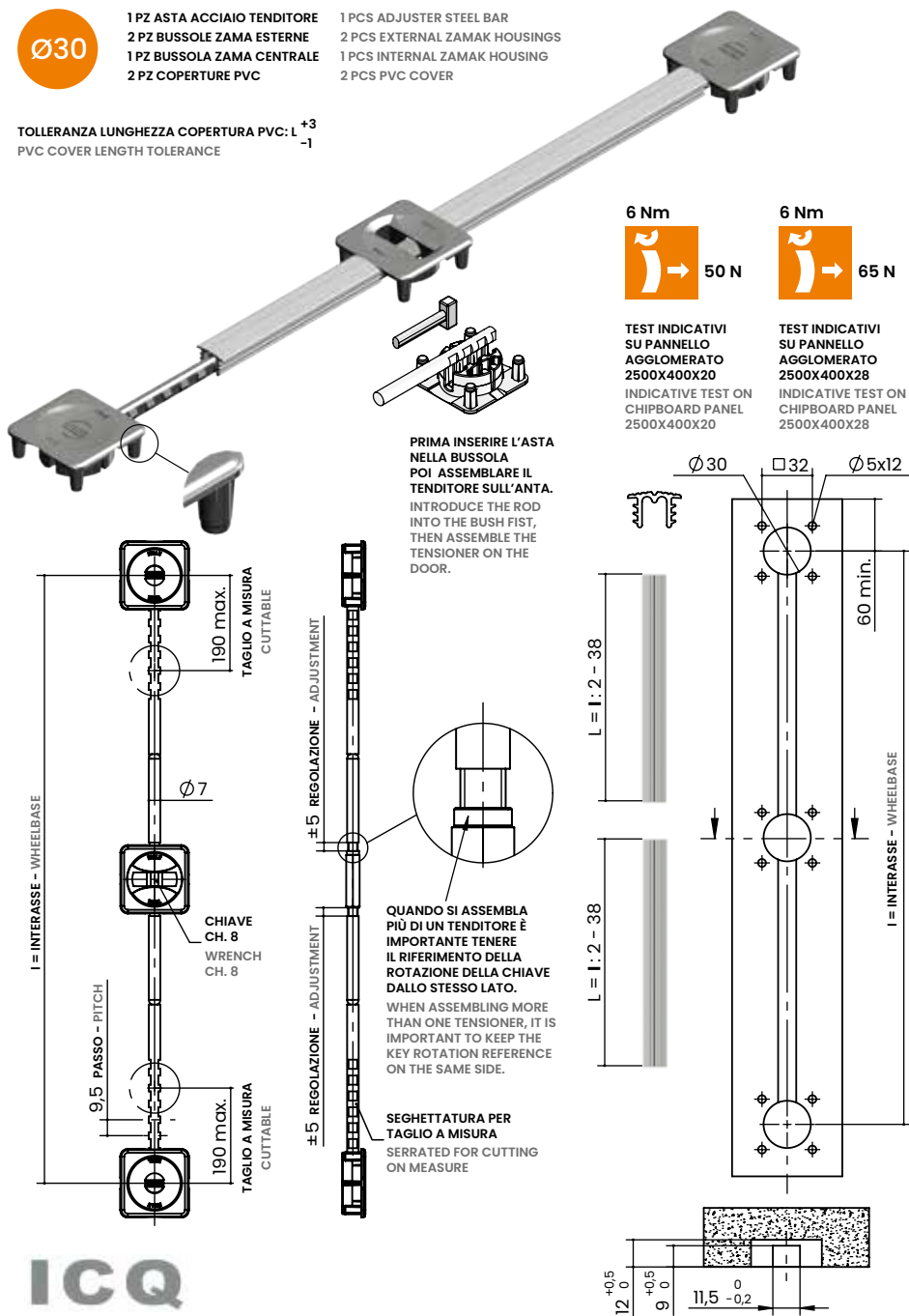

Normalmente assemblati su pannelli di legno o agglomerati e tamburati. Fissaggio senza viti.

Spessore minimo 16. Interasse min. 1200, max. 2800.

PER MAGGIORI DETTAGLI TECNICI CONSULTARE 'INFORMAZIONI GENERALI' A FINE CAPITOLO 6.

Normally assembled on wooden panels or agglomerates and hollow wood panels. Fixing without screws.

Minimum thickness 16. Centre distance min. 1200, max. 2800.

FOR MORE TECHNICAL DETAILS, PLEASE REFER TO 'GENERAL INFORMATION' AT THE END OF SECTION 6.

ACCESSORI ACCESSORIES

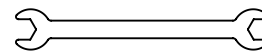

CHIAVE CH. 8
WRENCH CH. 8
P.A009.8

Per maggiori informazioni vedere sezione **10 ACCESSORI**

For further information see section **10 ACCESSORIES**

ULTERIORI COLORI PVC OTHER PVC COLORS

RD ARDESIA SLATE
MTL METALLIZZATO METAL GREY

ICQ
TEST REPORT 113710

TIPO TYPE	MISURA MEASURE	I INTERASSE WHEELBASE	FINITURA FINISHING	IMBALLO SU BANCALE PACKED ON PALLET KG / PZ	BOX 25 PZ KG / BOX	BOX 100 PZ KG / BOX
TN143.	1728.	1728	55 PVC GRIGIO GREY PVC	0,77	22	79
	1988.	1988	53 PVC NERO BLACK PVC	0,86	24	88
	2248.	2248	Minimo ordine 100 pz MOQ 100 pcs	0,96	25	98
	2330	2330	Misure a richiesta minimo ordine 300 pz Measure on request 300 pcs MO	0,98	26	100
	2600	2600		1,08	29	110

Codice composto con i dati evidenziati in arancione | Code composed with data highlighted in orange | es. e.g. TN143.2248.53

SERIE TN150

TN150 SERIES

I tenditori della serie TN150 sono normalmente assemblati su pannelli di legno o agglomerati. Utilizzati anche su pannelli di tamburato.

CARATTERISTICHE FONDAMENTALI:

- Regolazione centrale.
- Lavorazioni simmetriche.
- Sistema di fissaggio con o senza viti.

Spessore minimo pannello 16, regolazione ± 10 , interasse minimo 1200, interasse massimo 2800.

TN150 series tensioners are normally assembled on wooden panels or agglomerates. Also used on hollow wood panels.

KEY FEATURES:

- Central adjustment.
- Symmetric machining.
- Fixing system with or without screws.

Minimum panel thickness 16, adjustment ± 10 , minimum centre distance 1200, maximum centre distance 2800.

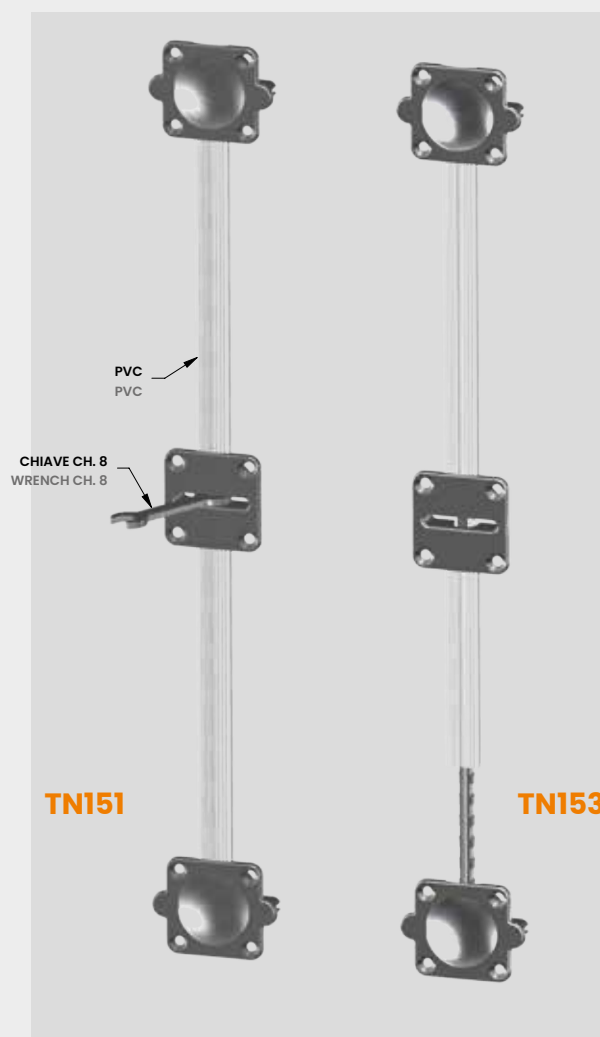

TN151

TENDITORI DA INCASSO

RECESSED WARDROBE ADJUSTERS



- 1 PZ ASTA ACCIAIO TENDITORE 1 PCS ADJUSTER STEEL BAR
- 2 PZ BUSSOLE ZAMA ESTERNE 2 PCS EXTERNAL ZAMAK HOUSINGS
- 1 PZ BUSSOLA ZAMA CENTRALE 1 PCS INTERNAL ZAMAK HOUSING
- 2 PZ COPERTURE PVC 2 PCS PVC COVER

TOLLERANZA LUNGHEZZA COPERTURA PVC: L +3
PVC COVER LENGTH TOLERANCE -1

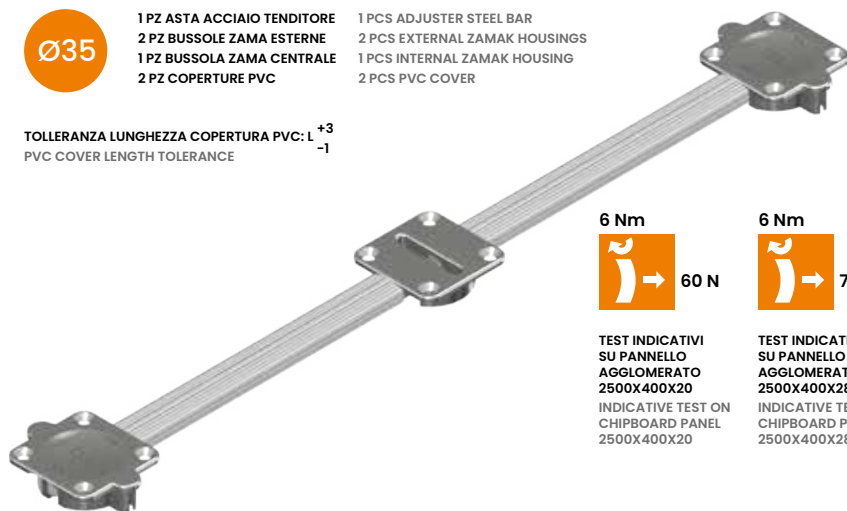

TEST INDICATIVI
SU PANNELLO
AGGLOMERATO
2500X400X20
INDICATIVE TEST ON
CHIPBOARD PANEL
2500X400X20



TEST INDICATIVI
SU PANNELLO
AGGLOMERATO
2500X400X28
INDICATIVE TEST ON
CHIPBOARD PANEL
2500X400X28

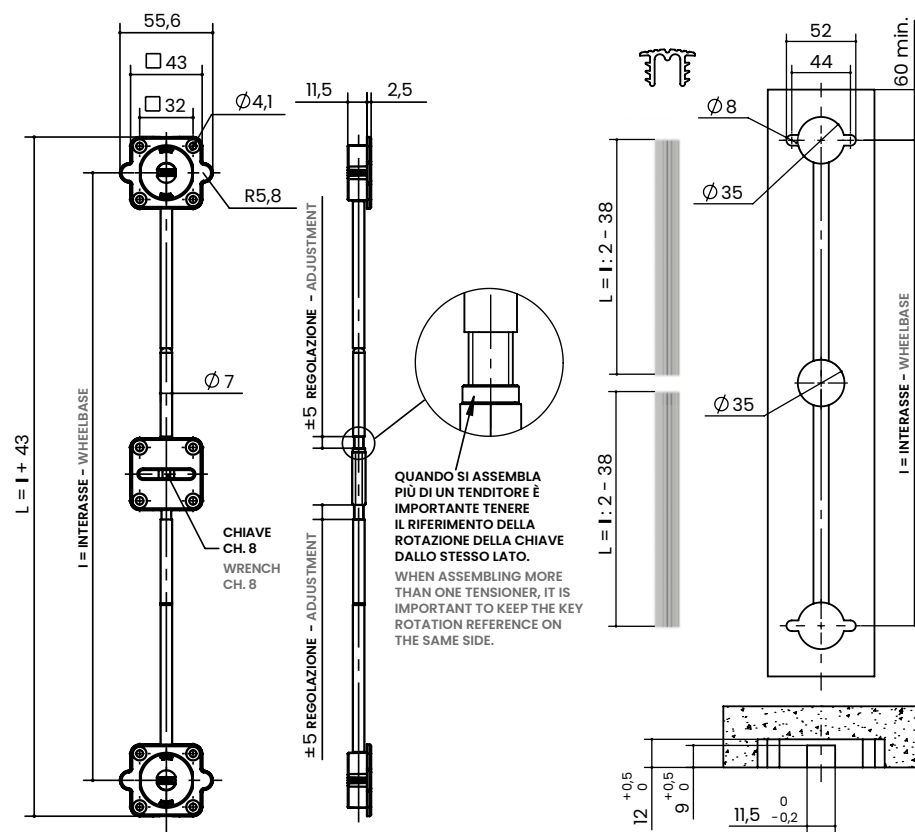

Normalmente assemblati su pannelli di legno o agglomerati e tamburati. Fissaggio con viti.

Spessore minimo 16. Interasse min. 1200, max. 2800.

PER MAGGIORI DETTAGLI TECNICI CONSULTARE 'INFORMAZIONI GENERALI' A FINE CAPITOLO 6.

Normally assembled on wooden panels or agglomerates and hollow wood panels. Fixing with screws.

Minimum thickness 16. Centre distance min. 1200, max. 2800.

FOR MORE TECHNICAL DETAILS, PLEASE REFER TO 'GENERAL INFORMATION' AT THE END OF SECTION 6.

ACCESSORI ACCESSORIES

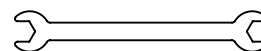

CHIAVE CH. 8
WRENCH CH. 8
P.A009.8

Per maggiori informazioni vedere sezione 10 ACCESSORI

For further information see section 10 ACCESSORIES

ULTERIORI COLORI PVC OTHER PVC COLORS

- RD ARDESIA SLATE
- MTL METALLIZZATO METAL GREY

TIPO TYPE	MISURA MEASURE	I INTERASSE WHEELBASE	FINITURA FINISHING	IMBALLO SU BANCALE PACKED ON PALLET KG / PZ	BOX 25 PZ KG / BOX	BOX 100 PZ KG / BOX
TN151.	1728.	1728	55 PVC GRIGIO GREY PVC	0,77	22	79
	1988.	1988	53 PVC NERO BLACK PVC	0,86	24	88
	2248.	2248	Minimo ordine 100 pz MOQ 100 pcs	0,96	25	98
	2329.	2329	Misure a richiesta minimo ordine 300 pz Measure on request 300 pcs MO	0,98	26	100
	2598.	2598		1,08	29	110

Codice composto con i dati evidenziati in arancione | Code composed with data highlighted in orange | es. e.g. TN151.2248.53

TN153

TENDITORI DA INCASSO TAGLIABILI CUTTABLE RECESSED WARDROBE ADJUSTERS



- 1 PZ ASTA ACCIAIO TENDITORE 1 PCS ADJUSTER STEEL BAR
- 2 PZ BUSSOLE ZAMA ESTERNE 2 PCS EXTERNAL ZAMAK HOUSINGS
- 1 PZ BUSSOLA ZAMA CENTRALE 1 PCS INTERNAL ZAMAK HOUSING
- 2 PZ COPERTURE PVC 2 PCS PVC COVER

TOLLERANZA LUNGHEZZA COPERTURA PVC: L +3
PVC COVER LENGTH TOLERANCE -1

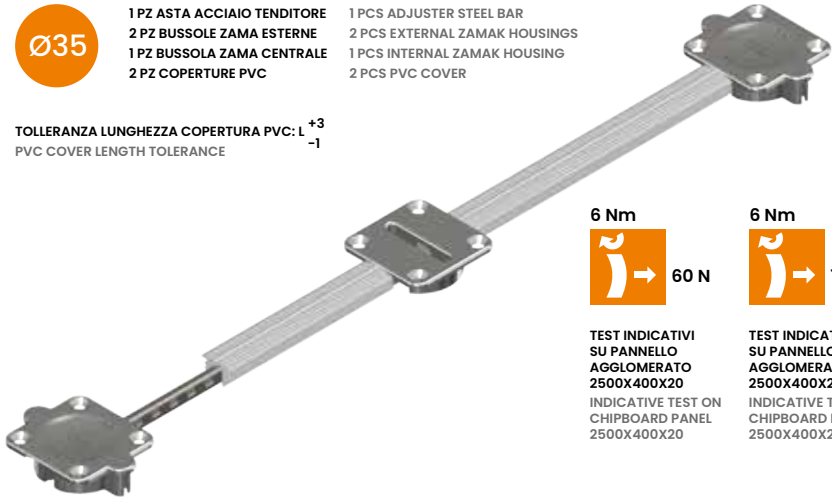

TEST INDICATIVI
SU PANNELLO
AGGLOMERATO
2500X400X20
INDICATIVE TEST ON
CHIPBOARD PANEL
2500X400X20



TEST INDICATIVI
SU PANNELLO
AGGLOMERATO
2500X400X28
INDICATIVE TEST ON
CHIPBOARD PANEL
2500X400X28

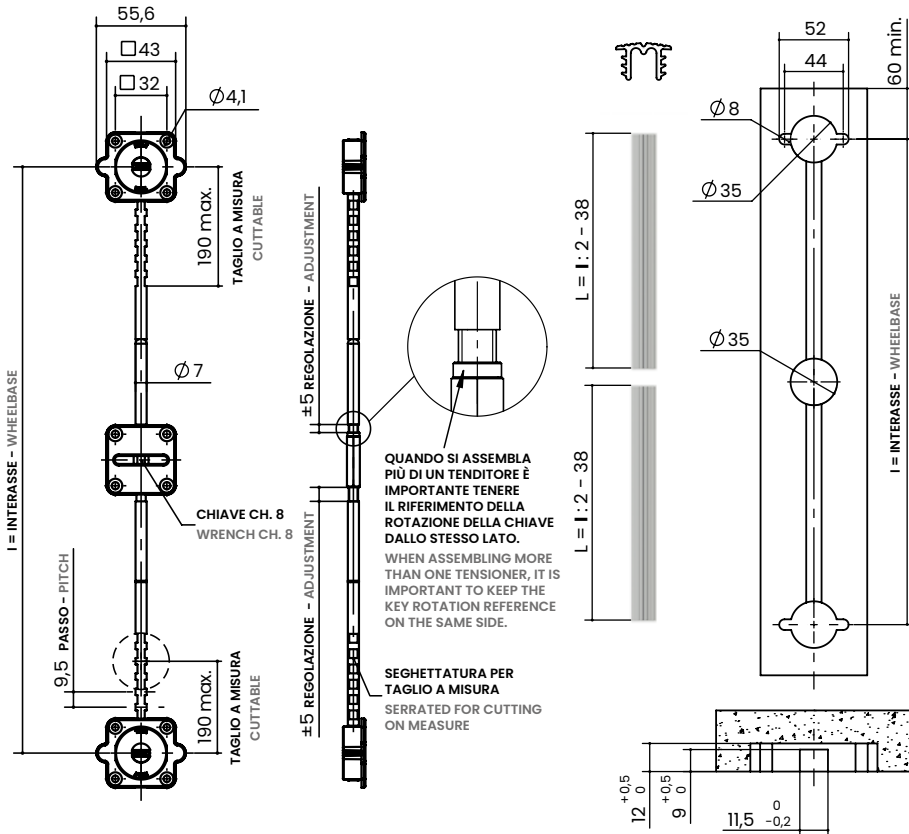

Normalmente assemblati su pannelli di legno o agglomerati e tamburati. Fissaggio con viti.

Spessore minimo 16. Interasse min. 1200, max. 2800.

PER MAGGIORI DETTAGLI TECNICI CONSULTARE 'INFORMAZIONI GENERALI' A FINE CAPITOLO 6.

Normally assembled on wooden panels or agglomerates and hollow wood panels. Fixing with screws.

Minimum thickness 16. Centre distance min. 1200, max. 2800.

FOR MORE TECHNICAL DETAILS, PLEASE REFER TO 'GENERAL INFORMATION' AT THE END OF SECTION 6.

ACCESSORI ACCESSORIES

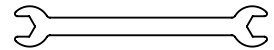

CHIAVE CH. 8
WRENCH CH. 8
P.A009.8

Per maggiori informazioni vedere sezione 10 ACCESSORI

For further information see section 10 ACCESSORIES

ULTERIORI COLORI PVC OTHER PVC COLORS

RD ARDESIA SLATE
MTL METALLIZZATO METAL GREY

TIPO TYPE	MISURA MEASURE	I INTERASSE WHEELBASE	FINITURA FINISHING	IMBALLO SU BANCALE PACKED ON PALLET KG / PZ	BOX 25 PZ KG / BOX	BOX 100 PZ KG / BOX
TN153.	1728.	1728	55 PVC GRIGIO GREY PVC	0,77	22	79
	1988.	1988	53 PVC NERO BLACK PVC	0,86	24	88
	2248.	2248	Minimo ordine 100 pz MOQ 100 pcs	0,96	25	98
	2329.	2329	Misure a richiesta minimo ordine 300 pz Measure on request 300 pcs MO	0,98	26	100
	2598.	2598		1,08	29	110

Codice composto con i dati evidenziati in arancione | Code composed with data highlighted in orange | es. e.g. TN153.2248.55

SERIE TN210

TN210 SERIES

Sono normalmente assemblati su pannelli di legno o agglomerati. Utilizzati anche su pannelli di tamburato. Spessore min. 16.

CARATTERISTICHE FONDAMENTALI:

Possibilità di regolazione:

- frontale nella parte superiore e inferiore con chiave fissa CH8 (inferiore solo per TN214);
- superiore e inferiore con chiave es.4 (inferiore solo per TN214).

L'asta unica offre il vantaggio di ridurre i componenti da assemblare e le lavorazioni.

Per il su misura è sufficiente tagliare da un lato.

Spessore minimo 16, regolazione ± 10 , interasse minimo 1200, interasse massimo 2800.

TN210 series tensioners are normally assembled on wooden panels or agglomerates. Also used on hollow wood panels. Minimum thickness 16.

KEY FEATURES:

Adjustment possibilities:

- front adjustment at the top and bottom with wrench CH8;
- adjustment at the top and bottom with hex. key 4 (bottom only for TN214).

The single rod has the advantage of reducing the parts to assemble and machining operations.

To customise just cut on one side.

Minimum thickness 16, adjustment ± 10 , minimum centre distance 1200, maximum centre distance 2800.



TN211

UNA REGOLAZIONE
ONE ADJUSTMENT



TN213

UNA REGOLAZIONE +
TAGLIABILE
ONE ADJUSTMENT +
CUTTABLE



TN214

DOPPIA REGOLAZIONE
DOUBLE ADJUSTMENT

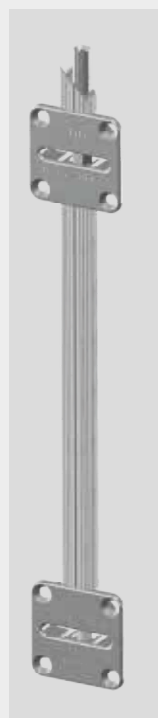

TN211P

CON PROLUNGA
WITH EXTENSION BAR



TN213P

CON PROLUNGA
+ TAGLIABILE
WITH EXTENSION BAR
+ CUTTABLE

TENDITORI - A vista
WARDROBE ADJUSTERS - Visible

TN211

TENDITORI DA INCASSO

RECESSED WARDROBE ADJUSTERS

- Ø35**
- 1 PZ ASTA ACCIAIO TENDITORE 1 PCS ADJUSTER STEEL BAR
 - 2 PZ BUSSOLE ZAMA ESTERNE 2 PCS EXTERNAL ZAMAK HOUSINGS
 - 1 PZ COPERTURE PVC 1 PCS PVC COVER

TOLLERANZA LUNGHEZZA COPERTURA PVC: L +3
 PVC COVER LENGTH TOLERANCE -1

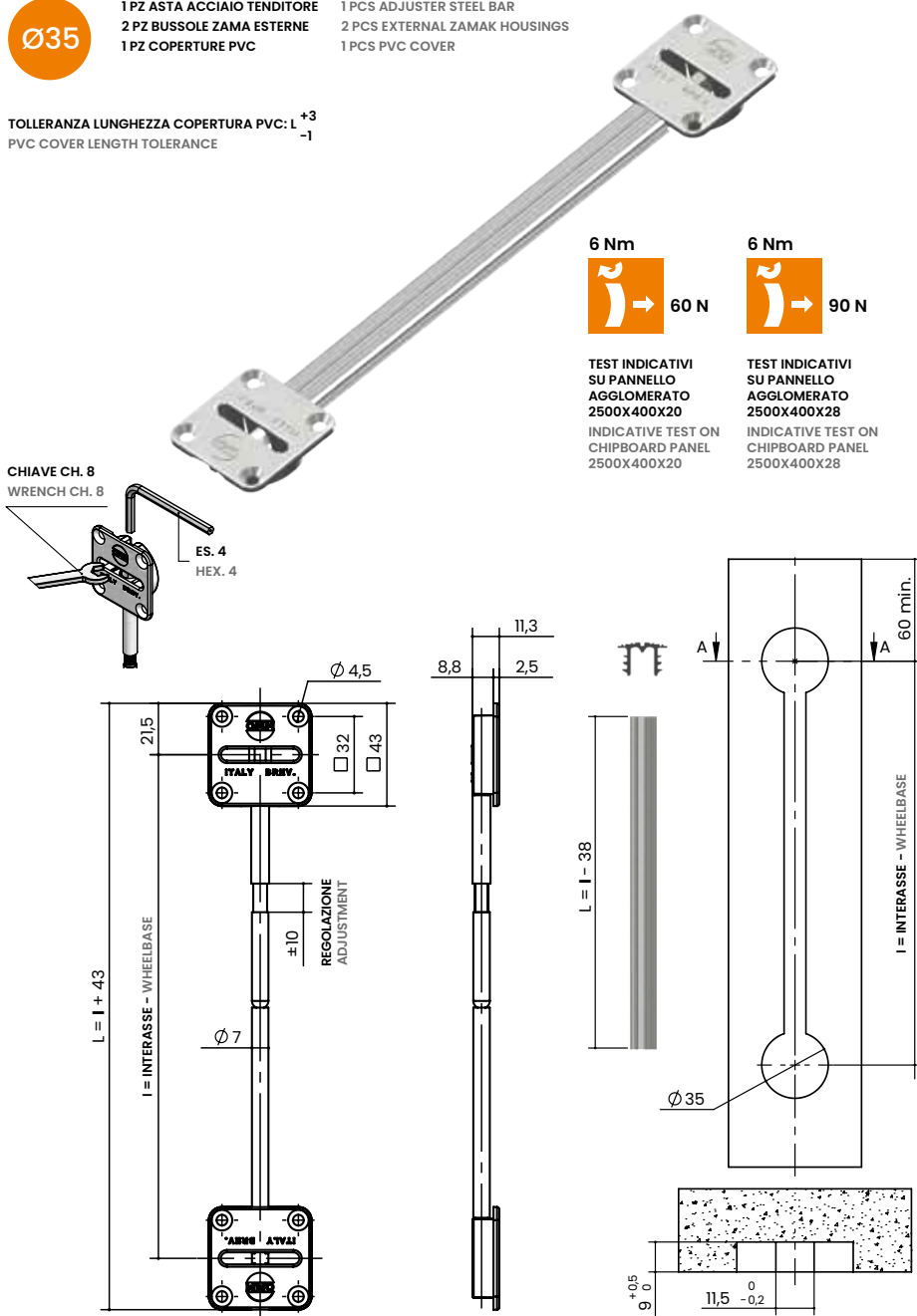

Normalmente assemblati su pannelli di legno o agglomerati e tamburati. Fissaggio con viti.

Spessore minimo 16. Interasse min. 1200, max. 2800.

PER MAGGIORI DETTAGLI TECNICI CONSULTARE 'INFORMAZIONI GENERALI' A FINE CAPITOLO 6.

Normally assembled on wooden panels or agglomerates and hollow wood panels. Fixing with screws.

Minimum thickness 16. Centre distance min. 1200, max. 2800.

FOR MORE TECHNICAL DETAILS, PLEASE REFER TO 'GENERAL INFORMATION' AT THE END OF SECTION 6.

ACCESSORI ACCESSORIES

- CHIAVE ES. 4
HEX. KEY 4
P.A087
- CHIAVE CH. 8
WRENCH CH. 8
P.A009.8
- COPRIBUSSOLA
COVER
P.T210

Per maggiori informazioni vedere sezione **10 ACCESSORI**

For further information see section **10 ACCESSORIES**

TIPO TYPE	MISURA MEASURE	I INTERASSE WHEELBASE	FINITURA FINISHING	IMBALLO SU BANCALE PACKED ON PALLET KG / PZ	BOX 25 PZ KG / BOX	BOX 100 PZ KG / BOX
TN211.	1740.	1740	55 PVC GRIGIO GREY PVC	0,72	18,1	72
	2040.	2040	53 PVC NERO BLACK PVC	0,83	20,9	83
	2195.	2195	Minimo ordine 100 pz MOQ 100 pcs	0,89	22,3	89
	2330.	2330	Misure a richiesta minimo ordine 300 pz Measure on request 300 pcs MO	0,94	23,5	94
	2600.	2600		1,05	26,3	105

Codice composto con i dati evidenziati in arancione | Code composed with data highlighted in orange | es. e.g. **TN211.2040.55**

TENDITORI - A vista
WARDROBE ADJUSTERS - Visible

TN211P

TENDITORI DA INCASSO

RECESSED WARDROBE ADJUSTERS



- 1 PZ ASTA ACCIAIO TENDITORE 1 PCS ADJUSTER STEEL BAR
- 2 PZ BUSSOLE ZAMA ESTERNE 2 PCS EXTERNAL ZAMAK HOUSINGS
- 1 PZ COPERTURE PVC 1 PCS PVC COVER

TOLLERANZA LUNGHEZZA COPERTURA PVC: L +3
 PVC COVER LENGTH TOLERANCE -1

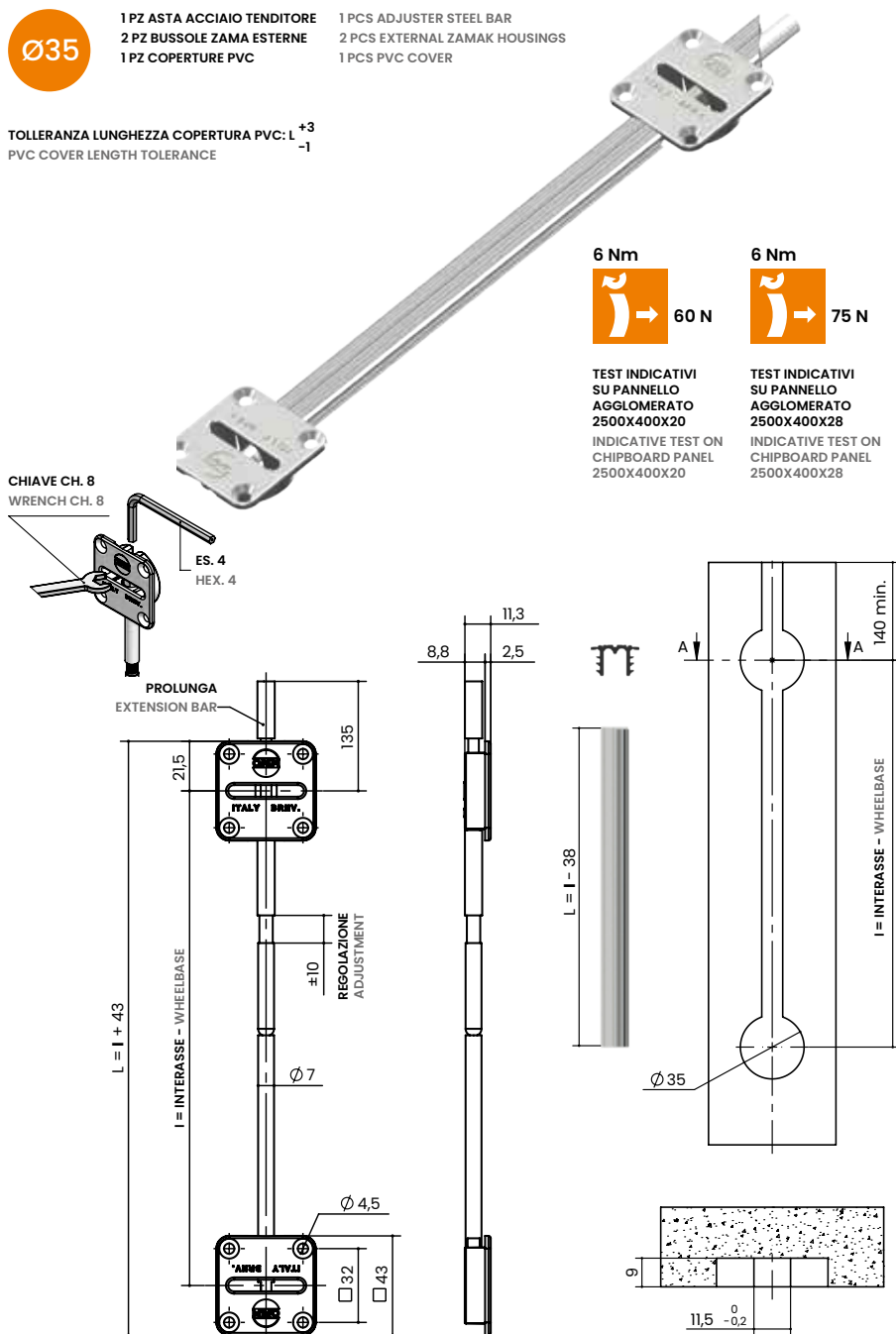

Normalmente assemblati su pannelli di legno o agglomerati e tamburati. Fissaggio con viti.

Spessore minimo 16.
 Interasse min. 1200,
 max. 2800.

PER MAGGIORI DETTAGLI TECNICI CONSULTARE 'INFORMAZIONI GENERALI' A FINE CAPITOLO 6.

Normally assembled on wooden panels or agglomerates and hollow wood panels. Fixing with screws.

Minimum thickness 16.
 Centre distance min. 1200,
 max. 2800.

FOR MORE TECHNICAL DETAILS, PLEASE REFER TO 'GENERAL INFORMATION' AT THE END OF SECTION 6.

ACCESSORI ACCESSORIES

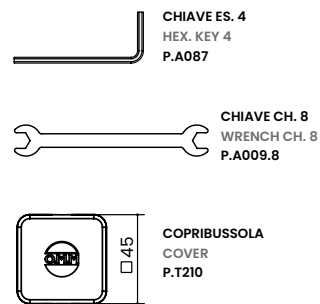

Per maggiori informazioni vedere sezione **10 ACCESSORI**

For further information see section **10 ACCESSORIES**

TIPO TYPE	MISURA MEASURE	I INTERASSE WHEELBASE	FINITURA FINISHING	IMBALLO SU BANCALE PACKED ON PALLET KG / PZ	BOX 25 PZ KG / BOX	BOX 100 PZ KG / BOX
TN211P.	1740.	1740	55 PVC GRIGIO GREY PVC	0,72	18,1	72
	2040.	2040	53 PVC NERO BLACK PVC	0,83	20,9	83
	2195.	2195	Minimo ordine 100 pz MOQ 100 pcs	0,89	22,3	89
	2330.	2330	Misure a richiesta minimo ordine 300 pz Measure on request 300 pcs MO	0,94	23,5	94
	2600.	2600		1,05	26,3	105

Codice composto con i dati evidenziati in arancione | Code composed with data highlighted in orange | es. e.g. **TN211P.2040.55**

TN213

TENDITORI DA INCASSO TAGLIABILI CUTTABLE RECESSED WARDROBE ADJUSTERS

- Ø35**
- 1 PZ ASTA ACCIAIO TENDITORE 1 PCS ADJUSTER STEEL BAR
 - 2 PZ BUSSOLE ZAMA ESTERNE 2 PCS EXTERNAL ZAMAK HOUSINGS
 - 1 PZ COPERTURE PVC 1 PCS PVC COVER

TOLLERANZA LUNGHEZZA COPERTURA PVC: L +3
PVC COVER LENGTH TOLERANCE -1

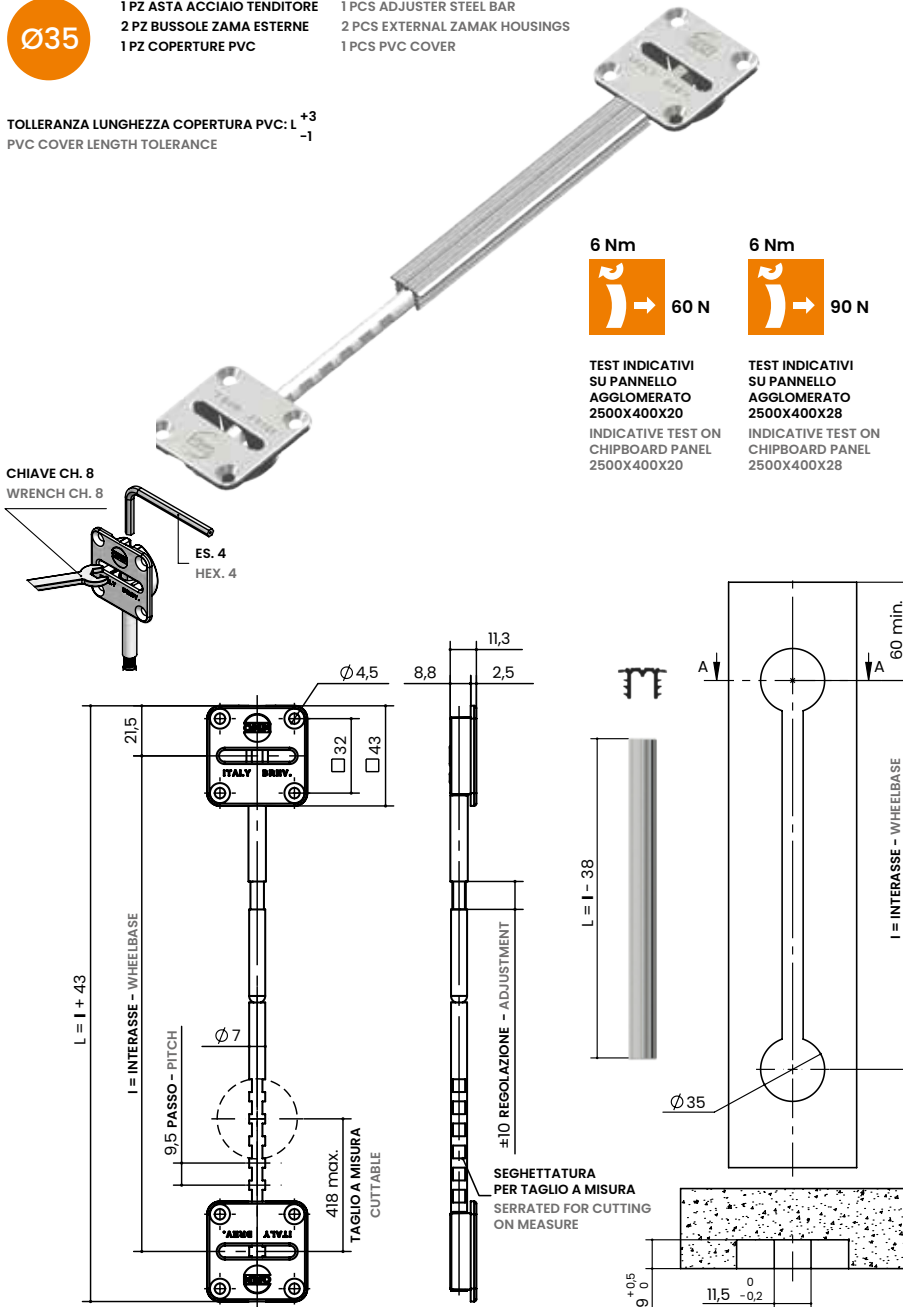

Normalmente assemblati su pannelli di legno o agglomerati e tamburati. Fissaggio con viti.

Spessore minimo 16. Interasse min. 1200, max. 2800.

PER MAGGIORI DETTAGLI TECNICI CONSULTARE 'INFORMAZIONI GENERALI' A FINE CAPITOLO 6.

Normally assembled on wooden panels or agglomerates and hollow wood panels. Fixing with screws.

Minimum thickness 16. Centre distance min. 1200, max. 2800.

FOR MORE TECHNICAL DETAILS, PLEASE REFER TO 'GENERAL INFORMATION' AT THE END OF SECTION 6.

ACCESSORI ACCESSORIES

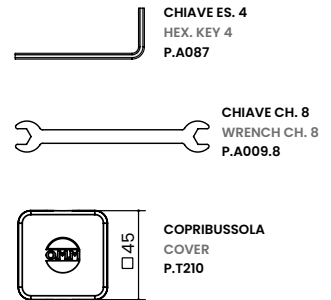

Per maggiori informazioni vedere sezione 10 ACCESSORI

For further information see section 10 ACCESSORIES

TIPO TYPE	MISURA MEASURE	I INTERASSE WHEELBASE	FINITURA FINISHING	IMBALLO SU BANCALE PACKED ON PALLET KG / PZ	BOX 25 PZ KG / BOX	BOX 100 PZ KG / BOX
TN213.	1740.	1740	55 PVC GRIGIO GREY PVC	0,72	18,1	72
	2040.	2040	53 PVC NERO BLACK PVC	0,83	20,9	83
	2195.	2195	Minimo ordine 100 pz MOQ 100 pcs	0,89	22,3	89
	2330.	2330	Misure a richiesta minimo ordine 300 pz Measure on request 300 pcs MO	0,94	23,5	94
	2600.	2600		1,05	26,3	105

Codice composto con i dati evidenziati in arancione | Code composed with data highlighted in orange | es. e.g. TN213.2040.53

TENDITORI - A vista
WARDROBE ADJUSTERS - Visible

TN213P

TENDITORI DA INCASSO TAGLIABILI CUTTABLE RECESSED WARDROBE ADJUSTERS

- Ø35**
- 1 PZ ASTA ACCIAIO TENDITORE 1 PCS ADJUSTER STEEL BAR
 - 2 PZ BUSSOLE ZAMA ESTERNE 2 PCS EXTERNAL ZAMAK HOUSINGS
 - 1 PZ COPERTURE PVC 1 PCS PVC COVER

TOLLERANZA LUNGHEZZA COPERTURA PVC: L +3
PVC COVER LENGTH TOLERANCE -1

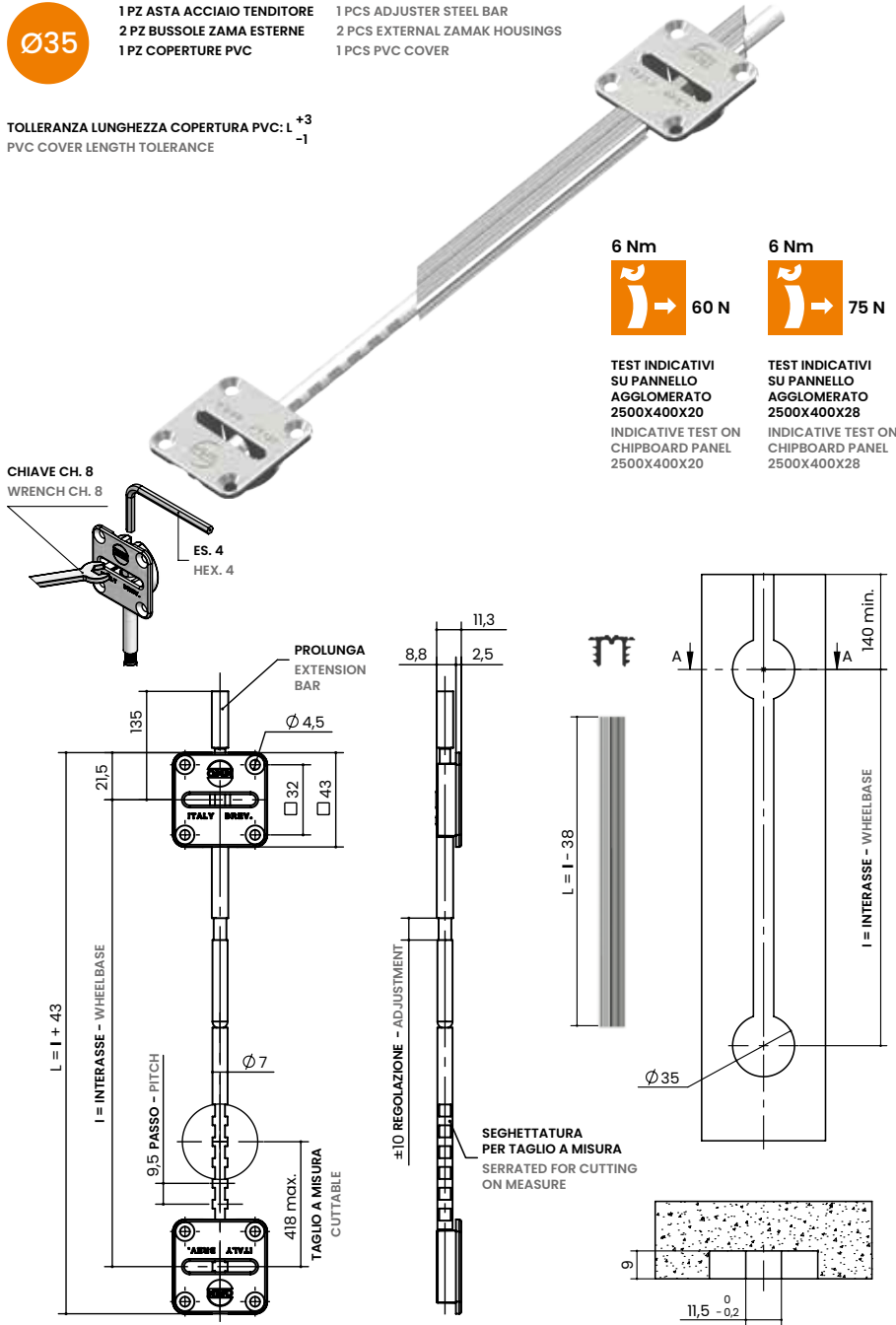

6 Nm
60 N

6 Nm
75 N

TEST INDICATIVI SU PANNELLO AGGLOMERATO 2500X400X20
INDICATIVE TEST ON CHIPBOARD PANEL 2500X400X20

TEST INDICATIVI SU PANNELLO AGGLOMERATO 2500X400X28
INDICATIVE TEST ON CHIPBOARD PANEL 2500X400X28

Normalmente assemblati su pannelli di legno o agglomerati e tamburati. Fissaggio con viti.

Spessore minimo 16. Interasse min. 1200, max. 2800.

PER MAGGIORI DETTAGLI TECNICI CONSULTARE 'INFORMAZIONI GENERALI' A FINE CAPITOLO 6.

Normally assembled on wooden panels or agglomerates and hollow wood panels. Fixing with screws.

Minimum thickness 16. Centre distance min. 1200, max. 2800.

FOR MORE TECHNICAL DETAILS, PLEASE REFER TO 'GENERAL INFORMATION' AT THE END OF SECTION 6.

ACCESSORI ACCESSORIES

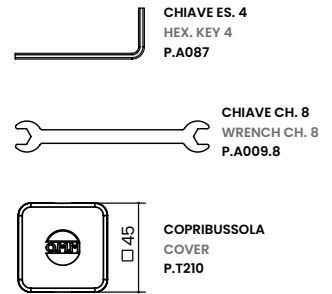

Per maggiori informazioni vedere sezione 10 ACCESSORI

For further information see section 10 ACCESSORIES

TIPO TYPE	MISURA MEASURE	I INTERASSE WHEELBASE	FINITURA FINISHING	IMBALLO SU BANCALE PACKED ON PALLET KG / PZ	BOX 25 PZ KG / BOX	BOX 100 PZ KG / BOX
TN213P.	1740.	1740	55 PVC GRIGIO GREY PVC	0,72	18,1	72
	2040.	2040	53 PVC NERO BLACK PVC	0,83	20,9	83
	2195.	2195	Minimo ordine 100 pz MOQ 100 pcs	0,89	22,3	89
	2330.	2330	Misure a richiesta minimo ordine 300 pz Measure on request 300 pcs MO	0,94	23,5	94
	2600.	2600		1,05	26,3	105

Codice composto con i dati evidenziati in arancione | Code composed with data highlighted in orange | es. e.g. TN213P.2040.53

SERIE TN220

TN220 SERIES

I tenditori della serie TN220 sono normalmente assemblati su pannelli di legno o agglomerati.

Utilizzati anche su pannelli di tamburato.
Spessore min. 16.

CARATTERISTICHE FONDAMENTALI:

Possibilità di regolazione:

- frontale nella parte superiore e inferiore con chiave fissa CH8 (inferiore solo per TN224);
- superiore e inferiore con chiave es.4 (inferiore solo per TN224).

L'asta unica offre il vantaggio di ridurre i componenti da assemblare e le lavorazioni.

Per il su misura è sufficiente tagliare da un lato.

Spessore minimo 16, regolazione ± 10 , interasse minimo 1200, interasse massimo 2800.

TN220 series tensioners are normally assembled on wooden panels or agglomerates.

Also used on hollow wood panels.
Minimum thickness 16.

KEY FEATURES:

Adjustment possibilities:

- front adjustment at the top and bottom with wrench CH8.
- adjustment at the top and bottom with hex. key 4 (bottom only for TN214).

The single rod has the advantage of reducing the parts to assemble and machining operations.

To customise just cut on one side.

Minimum thickness 16, adjustment ± 10 , minimum centre distance 1200, maximum centre distance 2800.



TN221

TENDITORI DA INCASSO

RECESSED WARDROBE ADJUSTERS



- 1 PZ ASTA ACCIAIO TENDITORE 1 PCS ADJUSTER STEEL BAR
- 2 PZ BUSSOLE ZAMA ESTERNE 2 PCS EXTERNAL ZAMAK HOUSINGS
- 1 PZ COPERTURE PVC 1 PCS PVC COVER

TOLLERANZA LUNGHEZZA COPERTURA PP: L +3
PP COVER LENGTH TOLERANCE -1



COPERTURA IN PP
RICICLATO E RICICLABILE
COVER IN RECYCLED PP
AND RECYCLABLE

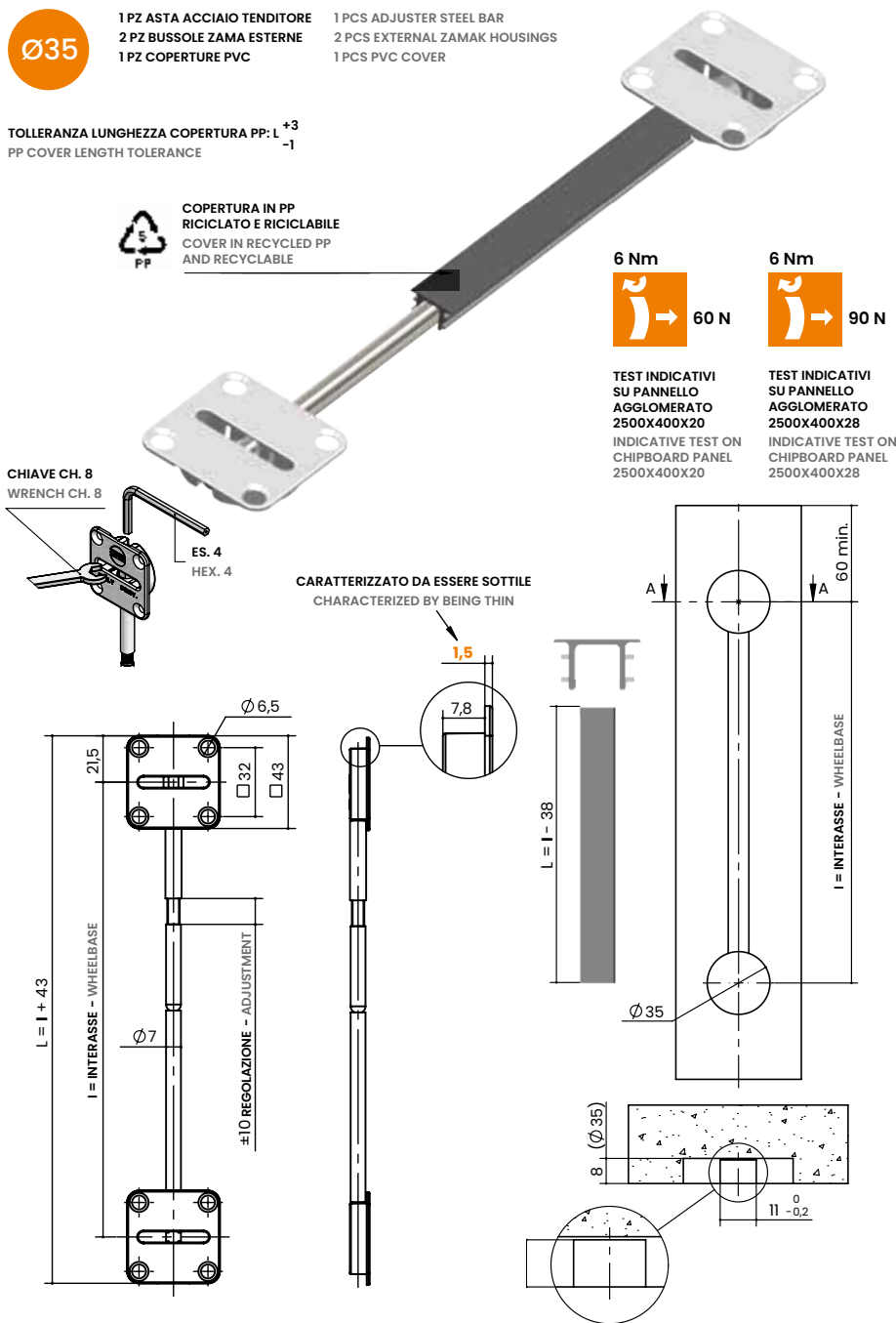

Normalmente assemblati su pannelli di legno o agglomerati e tamburati. Fissaggio con viti.

Spessore minimo 14. Interasse min. 1200, max. 2800.

PER MAGGIORI DETTAGLI TECNICI CONSULTARE 'INFORMAZIONI GENERALI' A FINE CAPITOLO 6.

Normally assembled on wooden panels or agglomerates and hollow wood panels. Fixing with screws.

Minimum thickness 14. Centre distance min. 1200, max. 2800.

FOR MORE TECHNICAL DETAILS, PLEASE REFER TO 'GENERAL INFORMATION' AT THE END OF SECTION 6.

ACCESSORI ACCESSORIES



CHIAVE ES. 4
HEX. KEY 4
P.A087

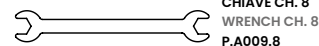

CHIAVE CH. 8
WRENCH CH. 8
P.A009.8



COPRIBUSSOLA
COVER
P.T220

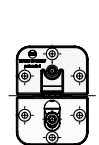

PLR.01.11.5.07
PLG.01.11.5.07

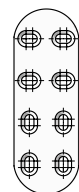

S.P.A576.AS

Per ante composte da due o più pannelli.

For doors composed of two or more panels.

Vedere sezione 10 ACCESSORI
See section 10 ACCESSORIES

TIPO TYPE	MISURA MEASURE	I INTERASSE WHEELBASE	FINITURA FINISHING	IMBALLO SU BANCALE PACKED ON PALLET KG / PZ	BOX 25 PZ KG / BOX	BOX 100 PZ KG / BOX
TN221.	1700.	1700	GMTL COPERTURA GRIGIA METALIZZATA METAL GREY COVER	0,65	16,3	65
	2000.	2000	53 ZAMA NICHELATA COPERTURA NERA NICKEL ZAMAK WITH BLACK COVER	0,75	19	75
	2300.	2300	Minimo ordine 100 pz MOQ 100 pcs	0,85	21,3	85
	2600.	2600	Misure a richiesta minimo ordine 300 pz Measure on request 300 pcs MO	0,95	24	95

Codice composto con i dati evidenziati in arancione | Code composed with data highlighted in orange | es. e.g. TN221.2300.GMTL

TN223

TENDITORI DA INCASSO TAGLIABILI CUTTABLE RECESSED WARDROBE ADJUSTERS



- 1 PZ ASTA ACCIAIO TENDITORE 1 PCS ADJUSTER STEEL BAR
- 2 PZ BUSSELE ZAMA ESTERNE 2 PCS EXTERNAL ZAMAK HOUSINGS
- 1 PZ COPERTURE PVC 1 PCS PVC COVER

TOLLERANZA LUNGHEZZA COPERTURA PP: L⁺³₋₁
PP COVER LENGTH TOLERANCE



COPERTURA IN PP
RICICLATO E RICICLABILE
COVER IN RECYCLED PP
AND RECYCLABLE

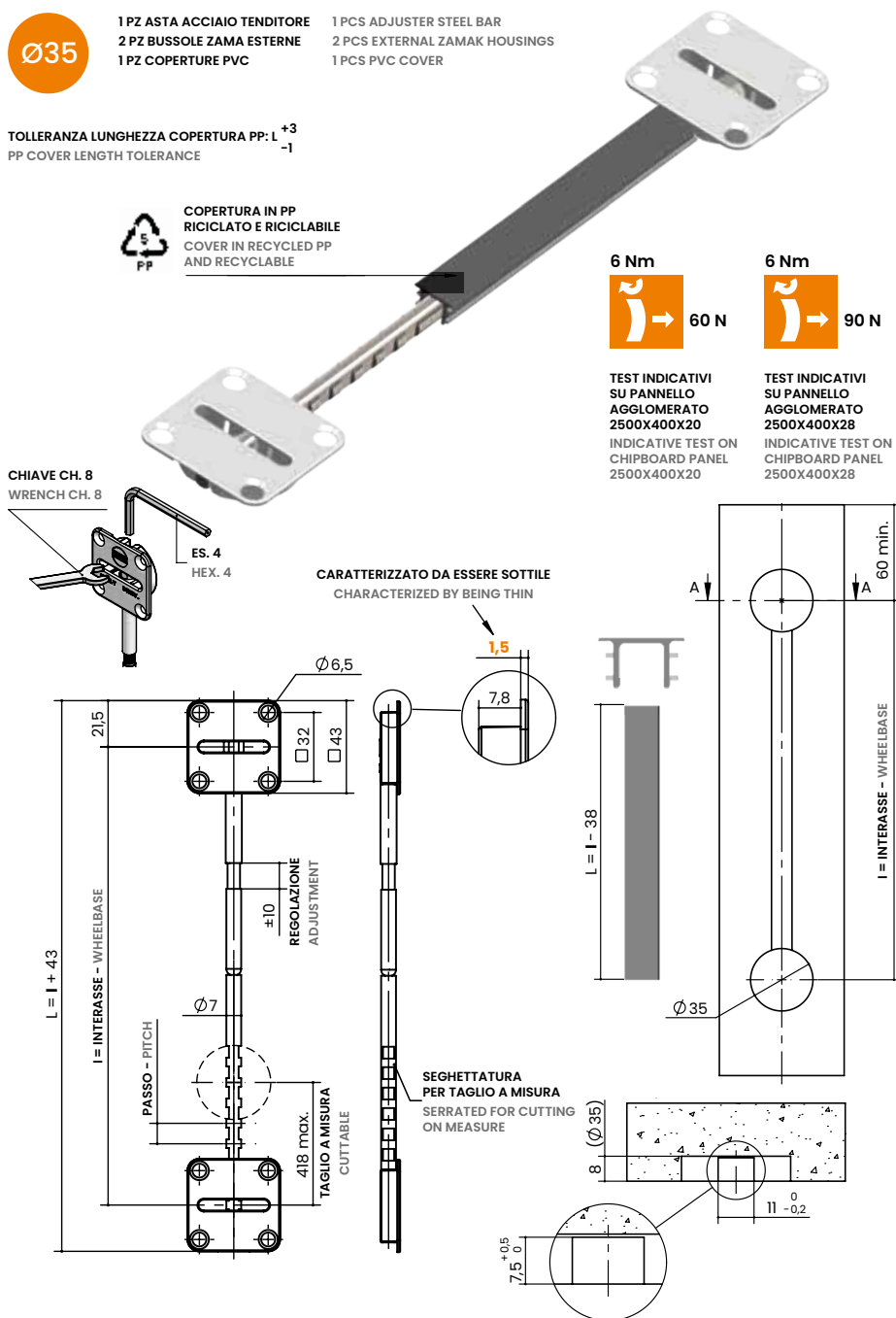

Normalmente assemblati su pannelli di legno o agglomerati e tamburati. Fissaggio con viti.

Spessore minimo 14.
Interasse min. 1200,
max. 2800.

PER MAGGIORI DETTAGLI TECNICI CONSULTARE 'INFORMAZIONI GENERALI' A FINE CAPITOLO 6.

Normally assembled on wooden panels or agglomerates and hollow wood panels. Fixing with screws.

Minimum thickness 14.
Centre distance min. 1200,
max. 2800.

FOR MORE TECHNICAL DETAILS, PLEASE REFER TO 'GENERAL INFORMATION' AT THE END OF SECTION 6.

ACCESSORI ACCESSORIES



CHIAVE ES. 4
HEX. KEY 4
P.A087

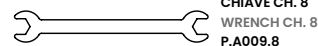

CHIAVE CH. 8
WRENCH CH. 8
P.A009.8



COPRIBUSSOLA
COVER
P.T220

Per maggiori informazioni vedere sezione 10 ACCESSORI

For further information see section 10 ACCESSORIES

TIPO TYPE	MISURA MEASURE	I INTERASSE WHEELBASE	FINITURA FINISHING	IMBALLO SU BANCALE PACKED ON PALLET KG / PZ	BOX 25 PZ KG / BOX	BOX 100 PZ KG / BOX
TN223.	1700.	1700	GMTL COPERTURA GRIGIA METALIZZATA METAL GREY COVER	0,65	16,3	65
	2000.	2000	53 ZAMA NICHELATA COPERTURA NERA NICKEL ZAMAK WITH BLACK COVER	0,75	19	75
	2300.	2300	Minimo ordine 100 pz MOQ 100 pcs	0,85	21,3	85
	2600.	2600	Misure a richiesta minimo ordine 300 pz Measure on request 300 pcs MO	0,95	24	95

Codice composto con i dati evidenziati in arancione | Code composed with data highlighted in orange | es. e.g. TN223.2300.GMTL

TN224

TENDITORI DA INCASSO

RECESSED WARDROBE ADJUSTERS



- 1 PZ ASTA ACCIAIO TENDITORE 1 PCS ADJUSTER STEEL BAR
- 2 PZ BUSSOLE ZAMA ESTERNE 2 PCS EXTERNAL ZAMAK HOUSINGS
- 1 PZ COPERTURE PVC 1 PCS PVC COVER

TOLLERANZA LUNGHEZZA COPERTURA PP: L⁺³₋₁
PP COVER LENGTH TOLERANCE



COPERTURA IN PP
RICICLATO E RICICLABILE
COVER IN RECYCLED PP
AND RECYCLABLE

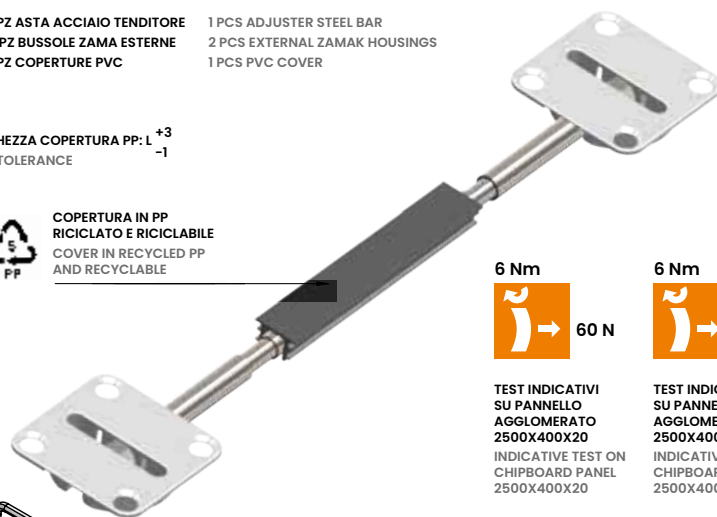

6 Nm



60 N

TEST INDICATIVI
SU PANNELLO
AGGLOMERATO
2500X400X20
INDICATIVE TEST ON
CHIPBOARD PANEL
2500X400X20

6 Nm



90 N

TEST INDICATIVI
SU PANNELLO
AGGLOMERATO
2500X400X28
INDICATIVE TEST ON
CHIPBOARD PANEL
2500X400X28

CHIAVE CH. 8
WRENCH CH. 8

ES. 4
HEX. 4

CARATTERIZZATO DA ESSERE SOTTILE
CHARACTERIZED BY BEING THIN

1,5

7,8

L = I - 38

60 min.

I = INTERASSE - WHEELBASE

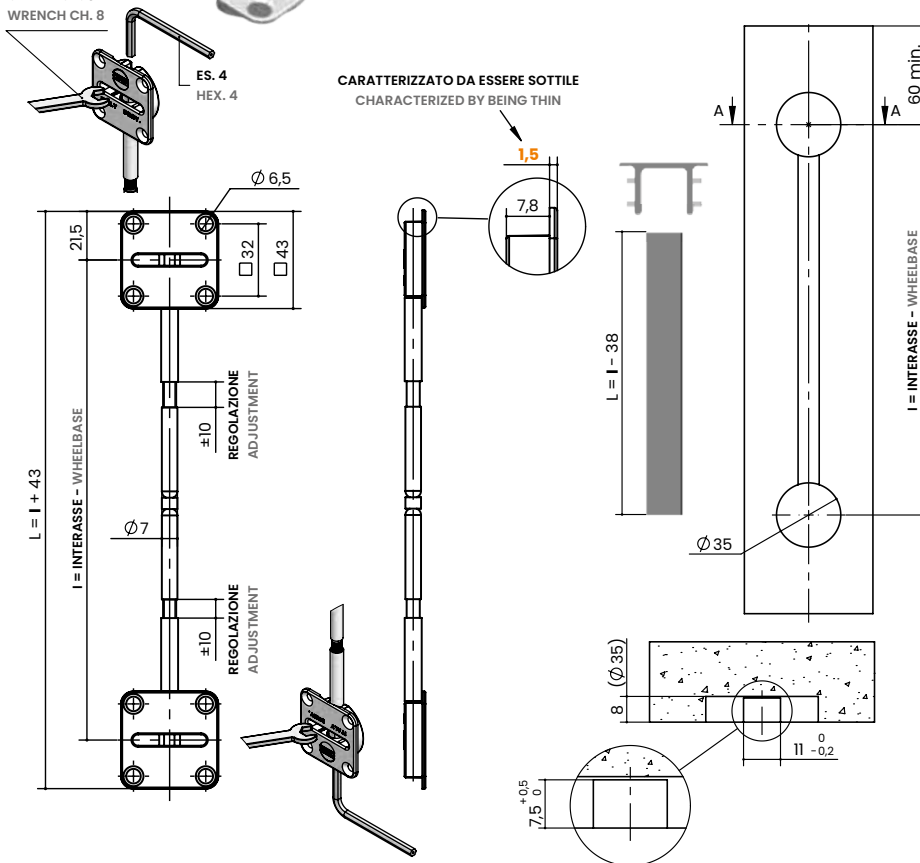

Normalmente assemblati su pannelli di legno o agglomerati e tamburati. Fissaggio con viti.

Spessore minimo 14.
Interasse min. 1200,
max. 2800.

PER MAGGIORI DETTAGLI TECNICI CONSULTARE
'INFORMAZIONI GENERALI' A FINE CAPITOLO 6.

Normally assembled on wooden panels or agglomerates and hollow wood panels. Fixing with screws.

Minimum thickness 14.
Centre distance min. 1200,
max. 2800.

FOR MORE TECHNICAL DETAILS, PLEASE
REFER TO 'GENERAL INFORMATION' AT THE
END OF SECTION 6.

ACCESSORI ACCESSORIES



CHIAVE ES. 4
HEX. KEY 4
P.A087

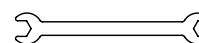

CHIAVE CH. 8
WRENCH CH. 8
P.A009.8

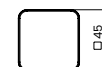

COPRIBUSSOLA
COVER
P.T220

Per maggiori informazioni
vedere sezione **10 ACCESSORI**

For further information see
section **10 ACCESSORIES**

TIPO TYPE	MISURA MEASURE	I INTERASSE WHEELBASE	FINITURA FINISHING	IMBALLO SU BANCALE PACKED ON PALLET KG / PZ	BOX 25 PZ KG / BOX	BOX 100 PZ KG / BOX
TN224.	1700.	1700	GMTL COPERTURA GRIGIA METALIZZATA METAL GREY COVER	0,65	16,3	65
	2000.	2000	53 ZAMA NICHELATA COPERTURA NERA NICKEL ZAMAK WITH BLACK COVER	0,75	19	75
	2300.	2300	Minimo ordine 100 pz MOQ 100 pcs Misure a richiesta minimo ordine 300 pz Measure on request 300 pcs MO	0,85	21,3	85
	2600.	2600		0,95	24	95

Codice composto con i dati evidenziati in arancione | Code composed with data highlighted in orange | es. e.g. TN224.2300.53

SERIE TN400

TN400 SERIES

I tenditori della serie TN400 sono normalmente assemblati su pannelli di tamburato.

CARATTERISTICHE FONDAMENTALI:

- Regolazione singola e doppia.
- La regolazione singola è normalmente posta sulla parte superiore.

Regolazione singola ± 10 , doppia ± 20 , interasse minimo 1200, massimo 2800.

TN400 series tensioners are normally assembled on hollow wood panels.

KEY FEATURES:

- Single and double adjustment.
- Single adjustment is normally placed on the top.

Adjustment: single ± 10 , double ± 20 , centre distance: minimum 1200, maximum 2800.

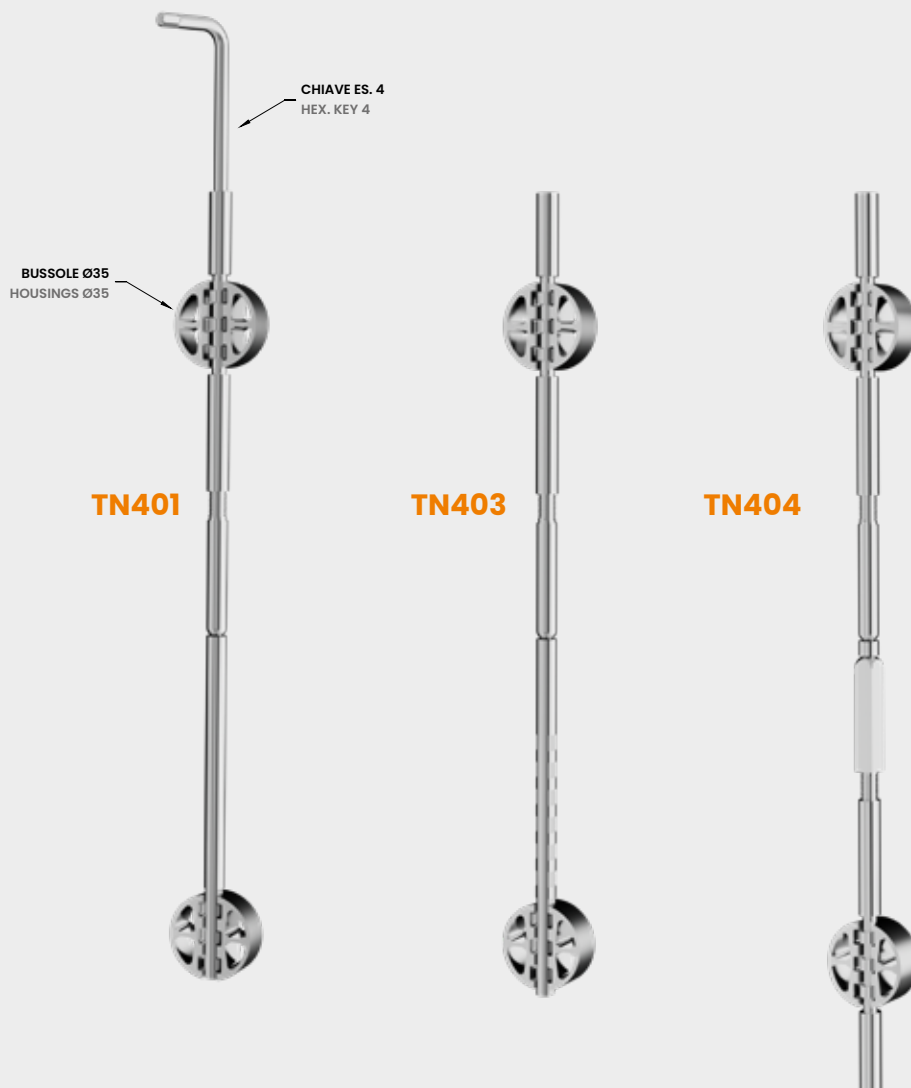

TN400

SCHEMA REGOLAZIONE TENDITORI

ADJUSTING SCHEME WARDROBE ADJUSTERS

Il tenditore lavora in entrambe le direzioni:

- girando la chiave in senso orario spinge in una direzione;
- girando la chiave in senso anti-orario spinge nell'altra direzione.

The tensioner works in both directions:

- turning the key clockwise pushes in one direction;
- turning the key anti-clockwise pushes in the other direction.

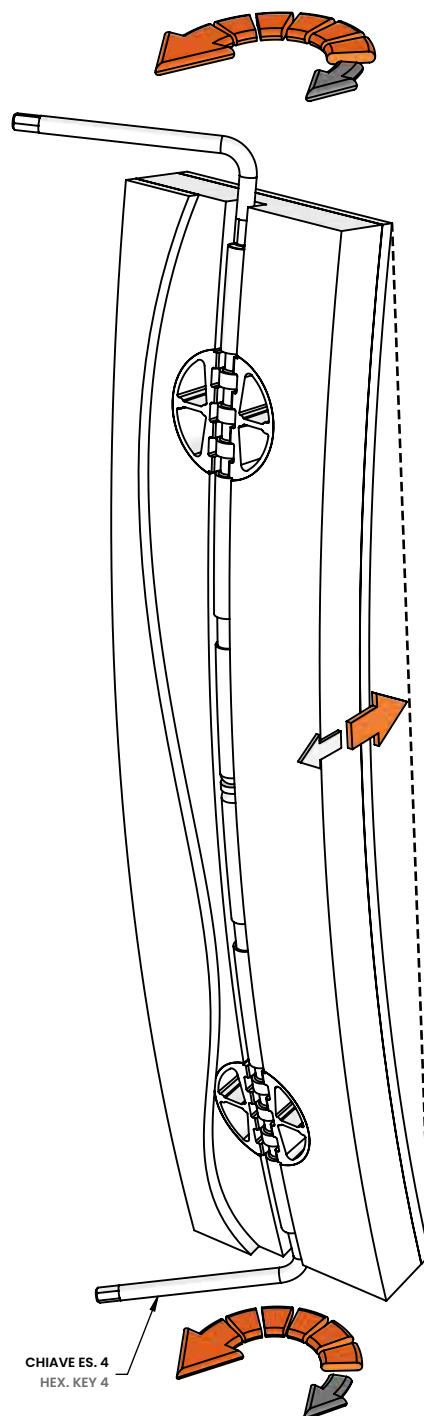

TN404

TN401

TENDITORI A SCOMPARSA

HIDDEN WARDROBE ADJUSTERS

- Ø35**
- 1 PZ ASTA ACCIAIO TENDITORE
 - 2 PZ BUSSOLE ZAMA ESTERNE
 - 1 PCS ADJUSTER STEEL BAR
 - 2 PCS EXTERNAL ZAMAK HOUSINGS

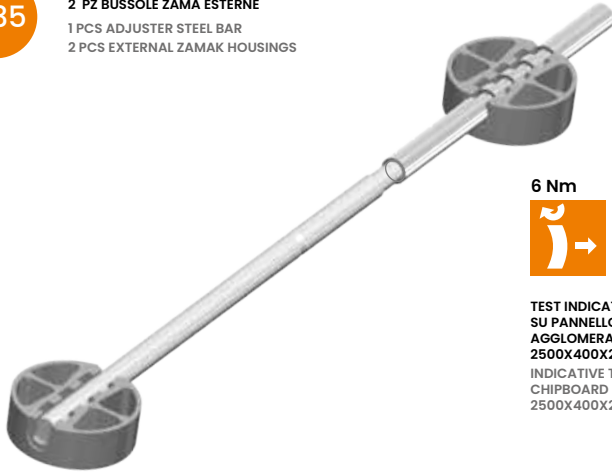

TEST INDICATIVI SU PANNELLO AGGLOMERATO 2500X400X20
 INDICATIVE TEST ON CHIPBOARD PANEL 2500X400X20



TEST INDICATIVI SU PANNELLO AGGLOMERATO 2500X400X28
 INDICATIVE TEST ON CHIPBOARD PANEL 2500X400X28

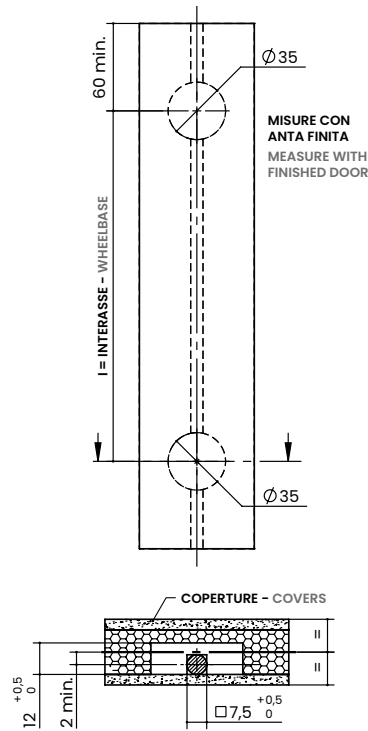
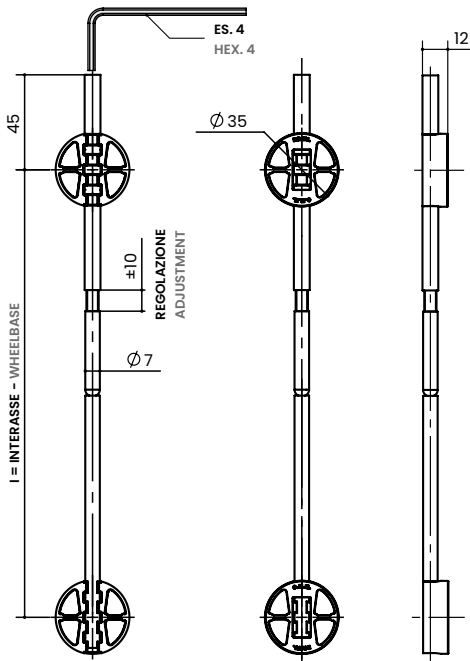

Normalmente utilizzati su pannelli di tamburato. Spessore minimo 18-20 a seconda dello spessore della copertura vedi fig. 1.

Regolazione singola e doppia. Interasse min. 1200, max. 2800.

PER MAGGIORI DETTAGLI TECNICI CONSULTARE 'INFORMAZIONI GENERALI' A FINE CAPITOLO 6.

Normally used on hollow wood panels. Minimum thickness 18-20, depending on the thickness of the cover, see fig. 1.

Single and double adjustment. Centre distance min. 1200, max. 2800.

FOR MORE TECHNICAL DETAILS, PLEASE REFER TO 'GENERAL INFORMATION' AT THE END OF SECTION 6.

ACCESSORI ACCESSORIES



CHIAVE ES. 4
HEX. KEY 4
P.A087

Per maggiori informazioni vedere sezione **10 ACCESSORI**

For further information see section **10 ACCESSORIES**

TIPO TYPE	MISURA MEASURE	I INTERASSE WHEELBASE	FINITURA FINISHING	IMBALLO SU BANCALE PACKED ON PALLET KG / PZ	BOX 25 PZ KG / BOX	BOX 100 PZ KG / BOX
TN401.	1700.	1700	00 GREZZO RAW Minimo ordine 100 pz MOQ 100 pcs Misure a richiesta minimo ordine 300 pz Measure on request 300 pcs MO	0,58	14,5	58
	1900.	1900		0,63	15,8	63
	2010.	2010		0,66	16,5	66
	2300.	2300		0,75	18,7	75
	2450.	2450		0,79	19,7	79
	2610.	2610		0,84	20,9	84
	2760.	2760		0,88	22	88
	2800.	2800		0,9	22,3	90

Codice composto con i dati evidenziati in arancione | Code composed with data highlighted in orange | es. e.g. **TN401.2300.00**

TN403

TENDITORI A SCOMPARSA TAGLIABILI CUTTABLE HIDDEN WARDROBE ADJUSTERS

- Ø35**
- 1 PZ ASTA ACCIAIO TENDITORE
 - 2 PZ BUSSOLE ZAMA ESTERNE
 - 1 PCS ADJUSTER STEEL BAR
 - 2 PCS EXTERNAL ZAMAK HOUSINGS



TEST INDICATIVI
 SU PANNELLO
 AGGLOMERATO
 2500X400X20
 INDICATIVE TEST ON
 CHIPBOARD PANEL
 2500X400X20



TEST INDICATIVI
 SU PANNELLO
 AGGLOMERATO
 2500X400X28
 INDICATIVE TEST ON
 CHIPBOARD PANEL
 2500X400X28

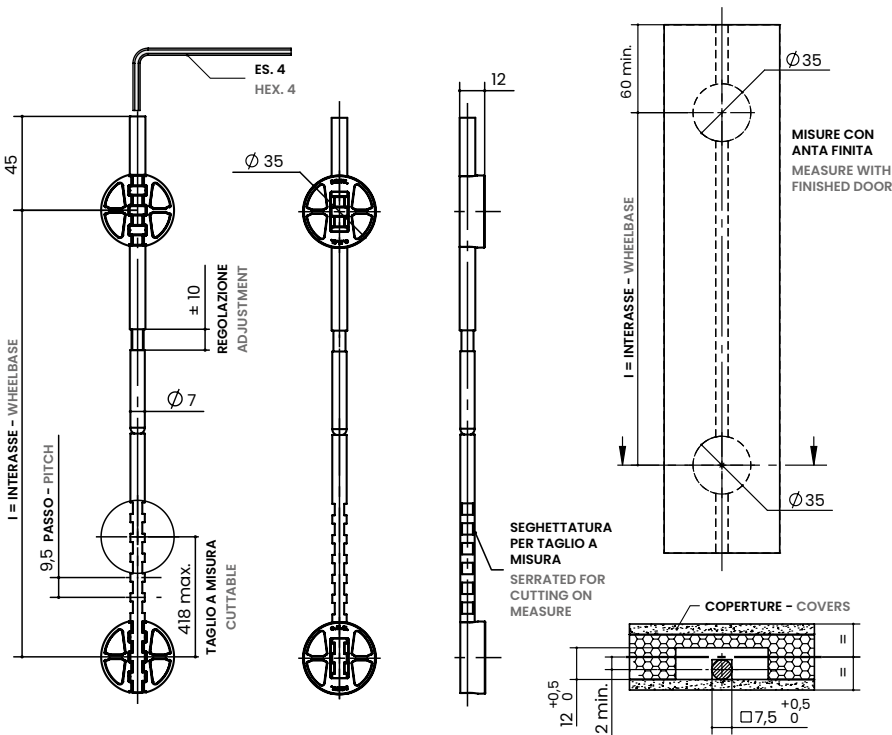

Normalmente utilizzati su pannelli di tamburato. Spessore minimo 18-20 a seconda dello spessore della copertura vedi fig. 1.

Regolazione singola e doppia. Interasse min. 1200, max. 2800.

PER MAGGIORI DETTAGLI TECNICI CONSULTARE 'INFORMAZIONI GENERALI' A FINE CAPITOLO 6.

Normally used on hollow wood panels. Minimum thickness 18-20, depending on the thickness of the cover, see fig. 1.

Single and double adjustment. Centre distance min. 1200, max. 2800.

FOR MORE TECHNICAL DETAILS, PLEASE REFER TO 'GENERAL INFORMATION' AT THE END OF SECTION 6.

ACCESSORI ACCESSORIES



CHIAVE ES. 4
 HEX. KEY 4
 P.A087

Per maggiori informazioni vedere sezione **10 ACCESSORI**

For further information see section **10 ACCESSORIES**

TIPO TYPE	MISURA MEASURE	I INTERASSE WHEELBASE	FINITURA FINISHING	IMBALLO SU BANCALE PACKED ON PALLET KG / PZ	BOX 25 PZ KG / BOX	BOX 100 PZ KG / BOX
TN403.	1700.	1700	00 GREZZO RAW Minimo ordine 100 pz MOQ 100 pcs Misure a richiesta minimo ordine 300 pz Measure on request 300 pcs MO	0,58	14,5	58
	1900.	1900		0,63	15,8	63
	2010.	2010		0,66	16,5	66
	2300.	2300		0,75	18,7	75
	2450.	2450		0,79	19,7	79
	2610.	2610		0,84	20,9	84
	2760.	2760		0,88	22	88
	2800.	2800		0,9	22,3	90

Codice composto con i dati evidenziati in arancione | Code composed with data highlighted in orange | es. e.g. **TN403.2300.00**

TN404

TENDITORI A SCOMPARSA

HIDDEN WARDROBE ADJUSTERS

- Ø35**
- 1 PZ ASTA ACCIAIO TENDITORE
 - 2 PZ BUSSOLE ZAMA ESTERNE
 - 1 PCS ADJUSTER STEEL BAR
 - 2 PCS EXTERNAL ZAMAK HOUSINGS

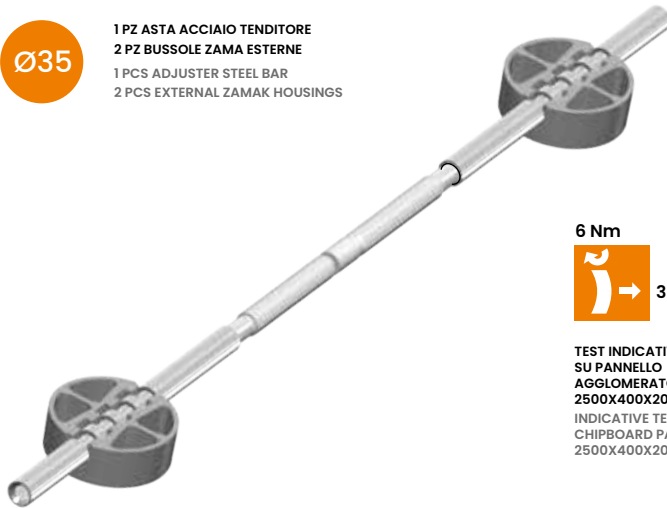

TEST INDICATIVI
 SU PANNELLO
 AGGLOMERATO
 2500X400X20
 INDICATIVE TEST ON
 CHIPBOARD PANEL
 2500X400X20



TEST INDICATIVI
 SU PANNELLO
 AGGLOMERATO
 2500X400X28
 INDICATIVE TEST ON
 CHIPBOARD PANEL
 2500X400X28

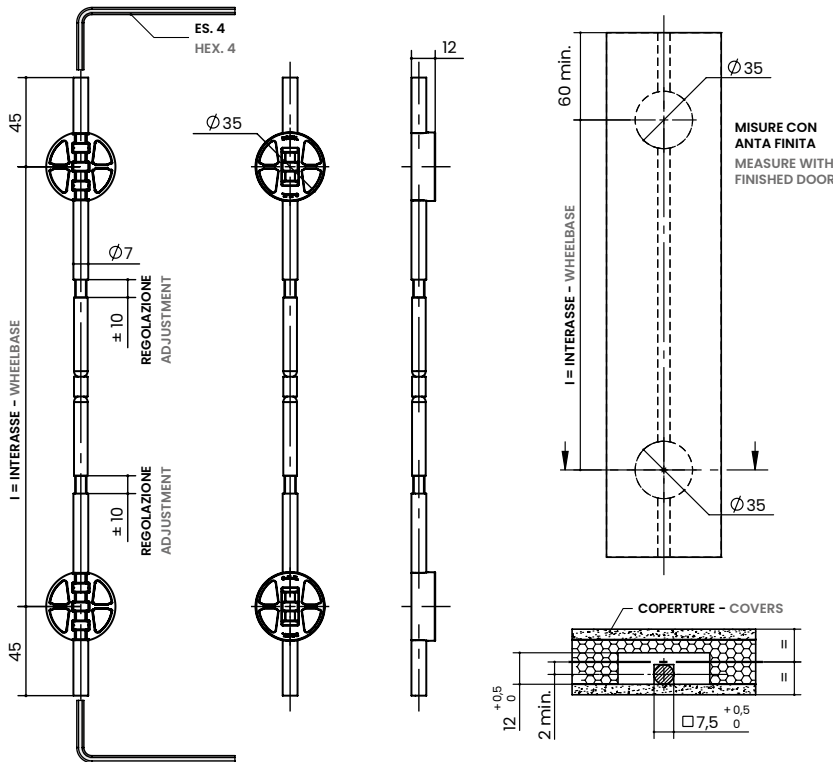

Normalmente utilizzati su pannelli di tamburato. Spessore minimo 18-20 a seconda dello spessore della copertura vedi fig. 1.

Regolazione singola e doppia. Interasse min. 1200, max. 2800.

PER MAGGIORI DETTAGLI TECNICI CONSULTARE 'INFORMAZIONI GENERALI' A FINE CAPITOLO 6.

Normally used on hollow wood panels. Minimum thickness 18-20, depending on the thickness of the cover, see fig. 1.

Single and double adjustment. Centre distance min. 1200, max. 2800.

FOR MORE TECHNICAL DETAILS, PLEASE REFER TO 'GENERAL INFORMATION' AT THE END OF SECTION 6.

ACCESSORI ACCESSORIES



CHIAVE ES. 4
 HEX. KEY 4
 P.A087

Per maggiori informazioni vedere sezione **10 ACCESSORI**

For further information see section **10 ACCESSORIES**

TIPO TYPE	MISURA MEASURE	I INTERASSE WHEELBASE	FINITURA FINISHING	IMBALLO SU BANCALE PACKED ON PALLET KG / PZ	BOX 25 PZ KG / BOX	BOX 100 PZ KG / BOX
TN404.	1700.	1700	00 GREZZO RAW Minimo ordine 100 pz MOQ 100 pcs Misure a richiesta minimo ordine 300 pz Measure on request 300 pcs MO	0,58	14,5	58
	1900.	1900		0,63	15,8	63
	2010.	2010		0,66	16,5	66
	2300.	2300		0,75	18,7	75
	2450.	2450		0,79	19,7	79
	2610.	2610		0,84	20,9	84
	2760.	2760		0,88	22	88
	2800.	2800		0,9	22,3	90

Codice composto con i dati evidenziati in arancione | Code composed with data highlighted in orange | es. e.g. **TN404.2300.00**

SERIE TN410

TN410 SERIES

I tenditori della serie TN410 sono normalmente assemblati su pannelli di tamburato.

CARATTERISTICHE FONDAMENTALI:

- Regolazione singola e doppia.
- La regolazione singola è normalmente posta sulla parte superiore.

Regolazione singola ± 10 , doppia ± 20 ; interasse minimo 1200, massimo 2800.

TN400 series tensioners are normally assembled on hollow wood panels.

KEY FEATURES:

- Single and double adjustment.
- Single adjustment is normally placed on the top.

Adjustment: single ± 10 , double ± 20 ; centre distance: minimum 1200, maximum 2800.

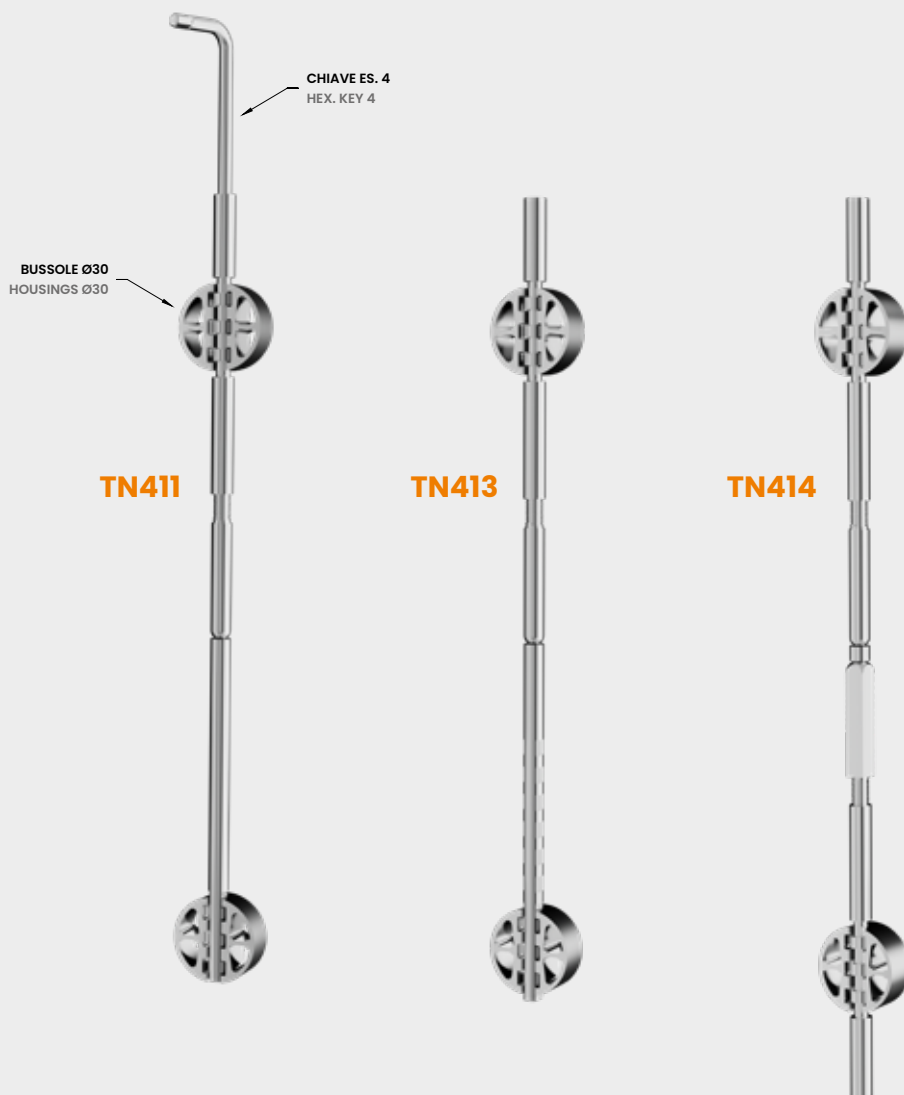

TN411

TENDITORI A SCOMPARSA

HIDDEN WARDROBE ADJUSTERS

- Ø30**
- 1 PZ ASTA ACCIAIO TENDITORE
 - 2 PZ BUSSOLE ZAMA ESTERNE
 - 1 PCS ADJUSTER STEEL BAR
 - 2 PCS EXTERNAL ZAMAK HOUSINGS

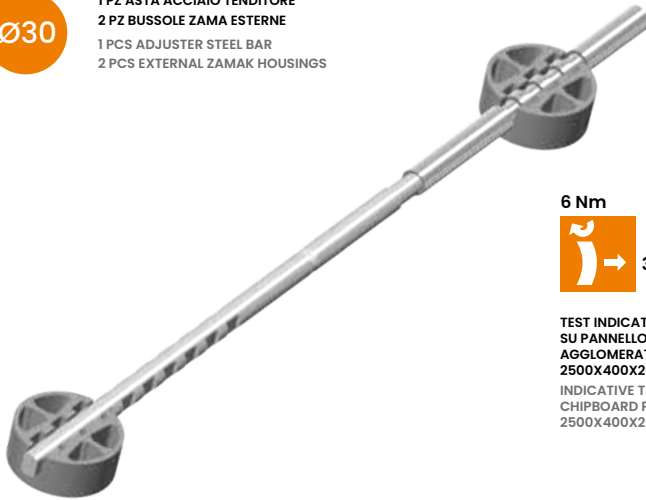

TEST INDICATIVI
 SU PANNELLO
 AGGLOMERATO
 2500X400X20
 INDICATIVE TEST ON
 CHIPBOARD PANEL
 2500X400X20



TEST INDICATIVI
 SU PANNELLO
 AGGLOMERATO
 2500X400X28
 INDICATIVE TEST ON
 CHIPBOARD PANEL
 2500X400X28

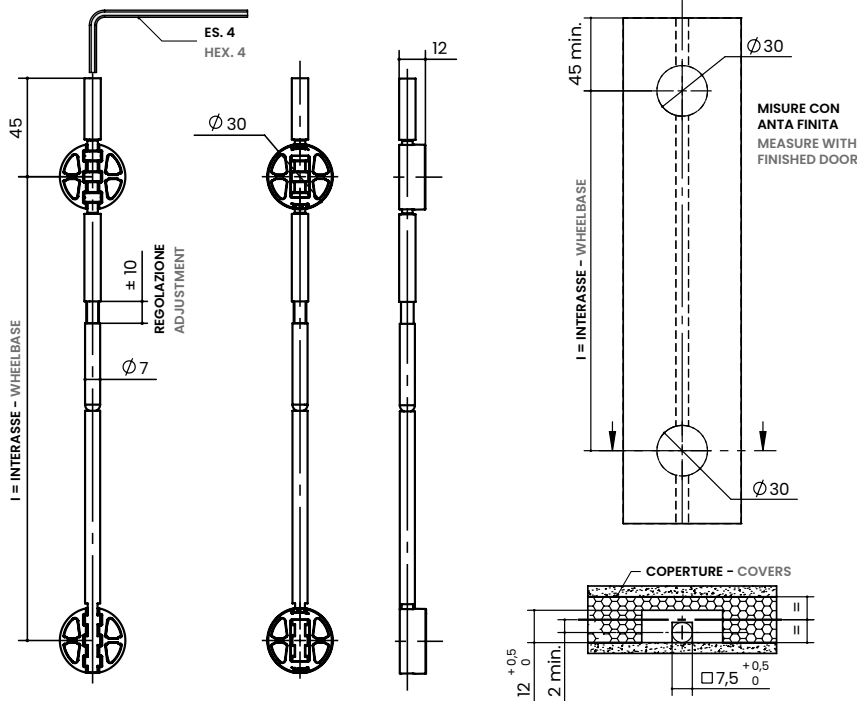

Normalmente utilizzati
 su pannelli di tamburato.
 Spessore minimo 18-20.

Regolazione singola e
 doppia.

Interasse min. 1200,
 max. 2800.

PER MAGGIORI DETTAGLI TECNICI CONSULTARE
 'INFORMAZIONI GENERALI' A FINE CAPITOLO 6.

Normally used on hollow
 wood panels. Minimum
 thickness 18-20.

Single and double
 adjustment.

Centre distance min. 1200,
 max. 2800.

FOR MORE TECHNICAL DETAILS, PLEASE
 REFER TO 'GENERAL INFORMATION' AT THE
 END OF SECTION 6.

ACCESSORI ACCESSORIES



CHIAVE ES. 4
 HEX. KEY 4
 P.A087

Per maggiori informazioni
 vedere sezione **10 ACCESSORI**

For further information see
 section **10 ACCESSORIES**

TIPO TYPE	MISURA MEASURE	I INTERASSE WHEELBASE	FINITURA FINISHING	IMBALLO SU BANCALE PACKED ON PALLET KG / PZ	BOX 25 PZ KG / BOX	BOX 100 PZ KG / BOX
TN411.	1700.	1700	00 GREZZO RAW Minimo ordine 100 pz MOQ 100 pcs Misure a richiesta minimo ordine 300 pz Measure on request 300 pcs MO	0,57	14,2	57
	1900.	1900		0,62	15,5	62
	2010.	2010		0,65	16,2	65
	2300.	2300		0,73	18,2	73
	2450.	2450		0,77	19,3	77
	2610.	2610		0,82	20,5	82
	2760.	2760		0,86	21,6	86
	2800.	2800		0,87	21,8	87

Codice composto con i dati evidenziati in arancione | Code composed with data highlighted in orange | es. e.g. **TN411.2300.00**

TN413

TENDITORI A SCOMPARSA TAGLIABILI CUTTABLE HIDDEN WARDROBE ADJUSTERS

- Ø30
 1 PZ ASTA ACCIAIO TENDITORE
 2 PZ BUSSOLE ZAMA ESTERNE
 1 PCS ADJUSTER STEEL BAR
 2 PCS EXTERNAL ZAMAK HOUSINGS

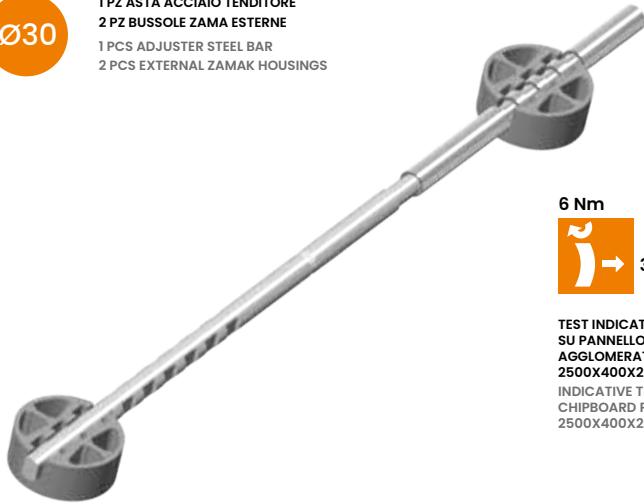

TEST INDICATIVI
SU PANNELLO
AGGLOMERATO
2500X400X20
INDICATIVE TEST ON
CHIPBOARD PANEL
2500X400X20



TEST INDICATIVI
SU PANNELLO
AGGLOMERATO
2500X400X28
INDICATIVE TEST ON
CHIPBOARD PANEL
2500X400X28

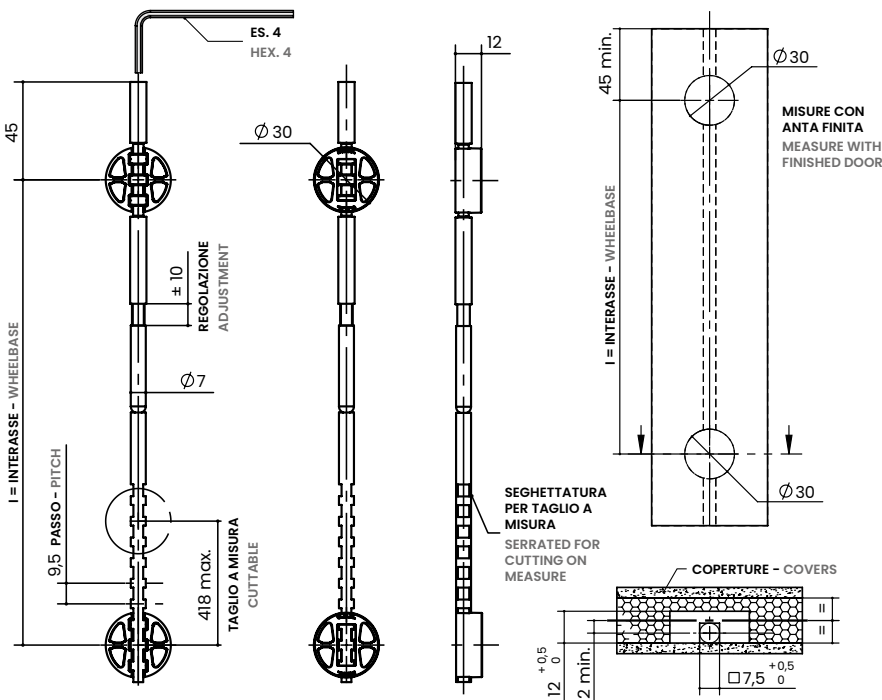

Normalmente utilizzati
su pannelli di tamburato.
Spessore minimo 18-20.

Regolazione singola e
doppia.

Interasse min. 1200,
max. 2800.

PER MAGGIORI DETTAGLI TECNICI CONSULTARE
'INFORMAZIONI GENERALI' A FINE CAPITOLO 6.

Normally used on hollow
wood panels. Minimum
thickness 18-20.

Single and double
adjustment.

Centre distance min. 1200,
max. 2800.

FOR MORE TECHNICAL DETAILS, PLEASE
REFER TO 'GENERAL INFORMATION' AT THE
END OF SECTION 6.

ACCESSORI ACCESSORIES



CHIAVE ES. 4
HEX. KEY 4
P.A087

Per maggiori informazioni
vedere sezione **10 ACCESSORI**

For further information see
section **10 ACCESSORIES**

TIPO TYPE	MISURA MEASURE	I INTERASSE WHEELBASE	FINITURA FINISHING	IMBALLO SU BANCALE PACKED ON PALLET KG / PZ	BOX 25 PZ KG / BOX	BOX 100 PZ KG / BOX
TN413.	1700.	1700	00 GREZZO RAW Minimo ordine 100 pz MOQ 100 pcs Misure a richiesta minimo ordine 300 pz Measure on request 300 pcs MO	0,57	14,2	57
	1900.	1900		0,62	15,5	62
	2010.	2010		0,65	16,2	65
	2300.	2300		0,73	18,2	73
	2450.	2450		0,77	19,3	77
	2610.	2610		0,82	20,5	82
	2760.	2760		0,86	21,6	86
	2800.	2800		0,87	21,8	87

Codice composto con i dati evidenziati in arancione | Code composed with data highlighted in orange | es. e.g. **TN413.2300.00**

TN414

TENDITORI A SCOMPARSA

HIDDEN WARDROBE ADJUSTERS

- Ø30**
- 1 PZ ASTA ACCIAIO TENDITORE
 - 2 PZ BUSSOLE ZAMA ESTERNE
 - 1 PCS ADJUSTER STEEL BAR
 - 2 PCS EXTERNAL ZAMAK HOUSINGS

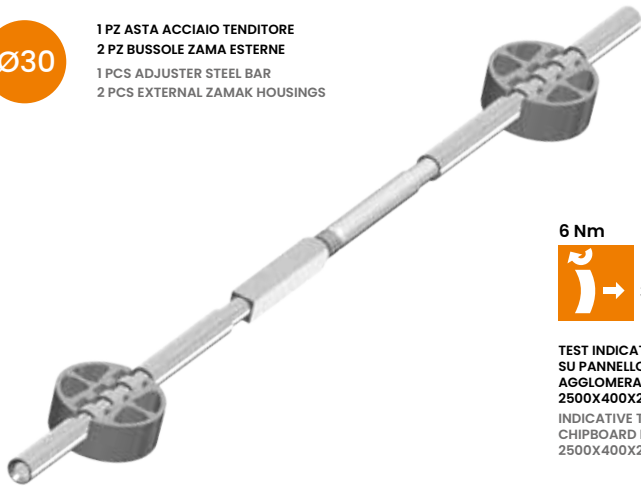

TEST INDICATIVI
SU PANNELLO
AGGLOMERATO
2500X400X20
INDICATIVE TEST ON
CHIPBOARD PANEL
2500X400X20



TEST INDICATIVI
SU PANNELLO
AGGLOMERATO
2500X400X28
INDICATIVE TEST ON
CHIPBOARD PANEL
2500X400X28

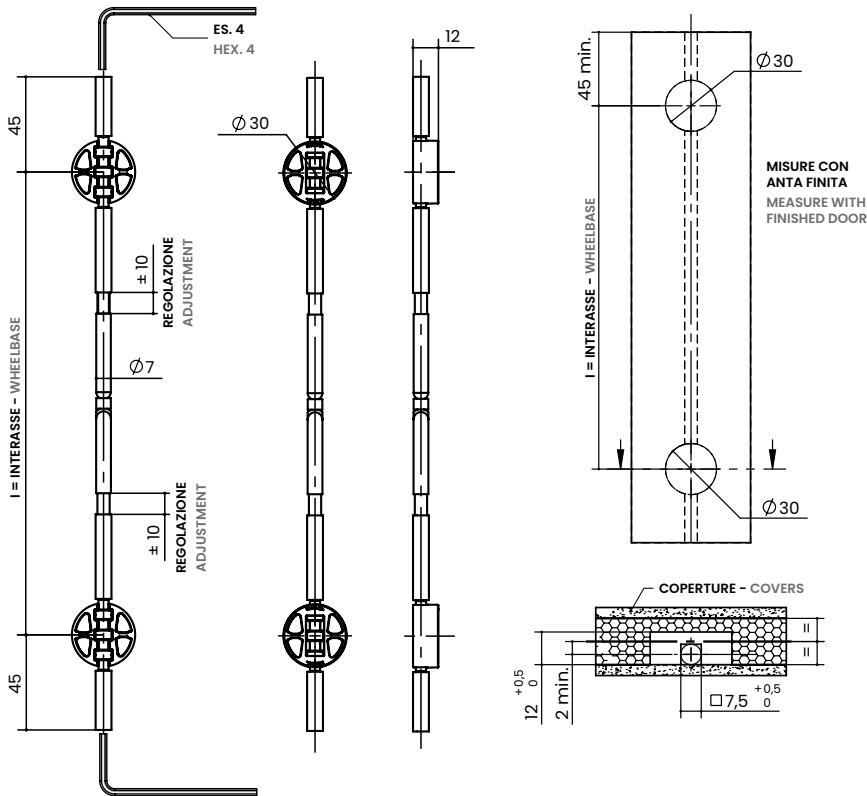

Normalmente utilizzati
su pannelli di tamburato.
Spessore minimo 18-20.

Regolazione singola e
doppia.

Interasse min. 1200
max. 2800.

PER MAGGIORI DETTAGLI TECNICI CONSULTARE
'INFORMAZIONI GENERALI' A FINE CAPITOLO 6.

Normally used on hollow
wood panels. Minimum
thickness 18-20.

Single and double
adjustment.

Centre distance min. 1200,
max. 2800.

FOR MORE TECHNICAL DETAILS, PLEASE
REFER TO 'GENERAL INFORMATION' AT THE
END OF SECTION 6.

ACCESSORI ACCESSORIES



CHIAVE ES. 4
HEX. KEY 4
P.A087

Per maggiori informazioni
vedere sezione **10 ACCESSORI**

For further information see
section **10 ACCESSORIES**

TIPO TYPE	MISURA MEASURE	I INTERASSE WHEELBASE	FINITURA FINISHING	IMBALLO SU BANCALE PACKED ON PALLET KG / PZ	BOX 25 PZ KG / BOX	BOX 100 PZ KG / BOX
TN414.	1700.	1700	00 GREZZO RAW Minimo ordine 100 pz MOQ 100 pcs Misure a richiesta minimo ordine 300 pz Measure on request 300 pcs MO	0,57	14,2	57
	1900.	1900		0,62	15,5	62
	2010.	2010		0,65	16,2	65
	2300.	2300		0,73	18,2	73
	2450.	2450		0,77	19,3	77
	2610.	2610		0,82	20,5	82
	2760.	2760		0,86	21,6	86
	2800.	2800		0,87	21,8	87

Codice composto con i dati evidenziati in arancione | Code composed with data highlighted in orange | es. e.g. **TN414.2300.00**

SERIE TN420

TN420 SERIES

I tenditori della serie TN400 sono normalmente assemblati su pannelli di tamburato.

CARATTERISTICHE FONDAMENTALI:

- Regolazione singola e doppia. La regolazione singola è normalmente posta sulla parte superiore.

Regolazione singola ± 10 , doppia ± 20 ; interasse minimo 1200, massimo 2800.

TN400 series tensioners are normally assembled on hollow wood panels.

KEY FEATURES:

- Single and double adjustment.
Single adjustment is normally placed on the top.

Adjustment: single ± 10 , double ± 20 ; centre distance: minimum 1200, maximum 2800.



TN421

TENDITORI A SCOMPARSA

HIDDEN WARDROBE ADJUSTERS

Ø35

1 PZ ASTA ACCIAIO TENDITORE
 CON ASSEMBLATE BUSSOLE
 ZAMA ESTERNE

1 PCS ADJUSTER STEEL BAR
 WITH ASSEMBLED EXTERNAL
 ZAMAK HOUSINGS

2 Nm



90 N

4 Nm



130 N

TEST INDICATIVI
 SU PANNELLO
 AGGLOMERATO
 2500X400X20

INDICATIVE TEST ON
 CHIPBOARD PANEL
 2500X400X20

TEST INDICATIVI
 SU PANNELLO
 AGGLOMERATO
 2500X400X28

INDICATIVE TEST ON
 CHIPBOARD PANEL
 2500X400X28

1 PCS ADJUSTER STEEL BAR
 WITH ASSEMBLED EXTERNAL
 ZAMAK HOUSINGS
 POSSIBILITY TO BLOCK IT ON
 THE PLAN WITH SCREWS

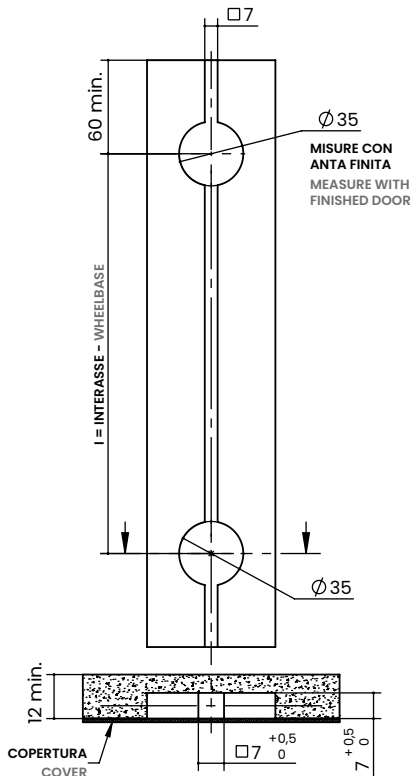
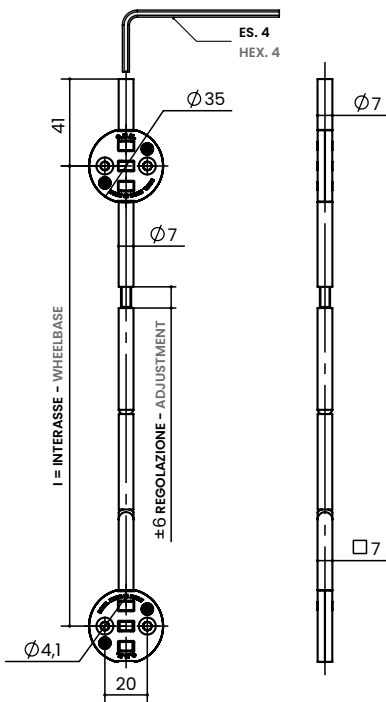
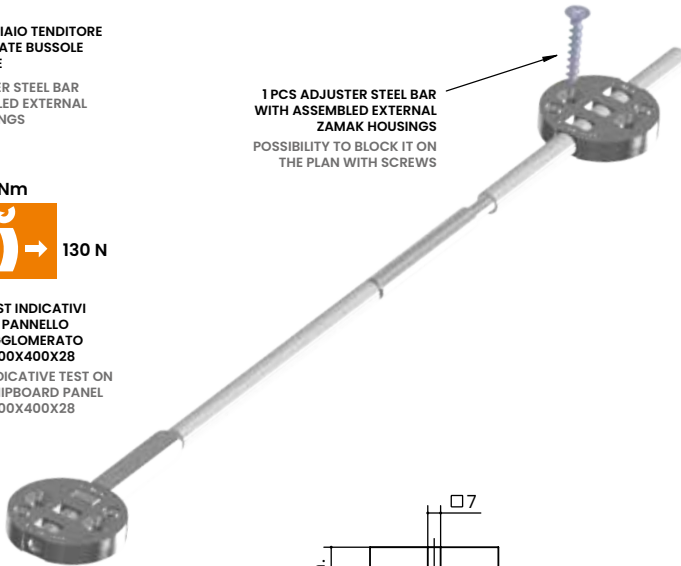

Normalmente utilizzati su pannelli di legno agglomerati assemblati esternamente o in tamburati di piccolo spessore. Interasse min. 1200, max. 2800.

PER MAGGIORI DETTAGLI TECNICI CONSULTARE 'INFORMAZIONI GENERALI' A FINE CAPITOLO 6.

Normally used on wooden panels agglomerated or hollow wood panels. Recommended for assembly under the covers in wood veneer. Single adjustment. Centre distance min. 1200, max. 2800.

FOR MORE TECHNICAL DETAILS, PLEASE REFER TO 'GENERAL INFORMATION' AT THE END OF SECTION 6.

ACCESSORI ACCESSORIES



CHIAVE ES. 4
 HEX. KEY 4
 P.A087

Per maggiori informazioni vedere sezione **10 ACCESSORI**

For further information see section **10 ACCESSORIES**

TIPO TYPE	MISURA MEASURE	I INTERASSE WHEELBASE	FINITURA FINISHING	IMBALLO SU BANCALE PACKED ON PALLET KG / PZ	BOX 25 PZ KG / BOX	BOX 100 PZ KG / BOX
TN421.	1700.	1700	00 GREZZO RAW Minimo ordine 100 pz MOQ 100 pcs Misure a richiesta minimo ordine 300 pz Measure on request 300 pcs MO	0,57	14,2	57
	1900.	1900		0,62	15,5	62
	2010.	2010		0,65	16,2	65
	2300.	2300		0,73	18,2	73
	2450.	2450		0,77	19,3	77
	2610.	2610		0,82	20,5	82
	2760.	2760		0,86	21,6	86
	2800.	2800		0,87	21,8	87

Codice composto con i dati evidenziati in arancione | Code composed with data highlighted in orange | es. e.g. **TN421.2300.00**

TN423

TENDITORI A SCOMPARSA TAGLIABILI CUTTABLE HIDDEN WARDROBE ADJUSTERS

Ø35

1 PZ ASTA ACCIAIO TENDITORE
CON ASSEMBLATE BUSSOLE
ZAMA ESTERNE

1 PCS ADJUSTER STEEL BAR WITH ASSEMBLED
EXTERNAL ZAMAK HOUSINGS

2 Nm



90 N

4 Nm



130 N

TEST INDICATIVI
SU PANNELLO
AGGLOMERATO
2500X400X20

INDICATIVE TEST ON
CHIPBOARD PANEL
2500X400X20

TEST INDICATIVI
SU PANNELLO
AGGLOMERATO
2500X400X28

INDICATIVE TEST ON
CHIPBOARD PANEL
2500X400X28

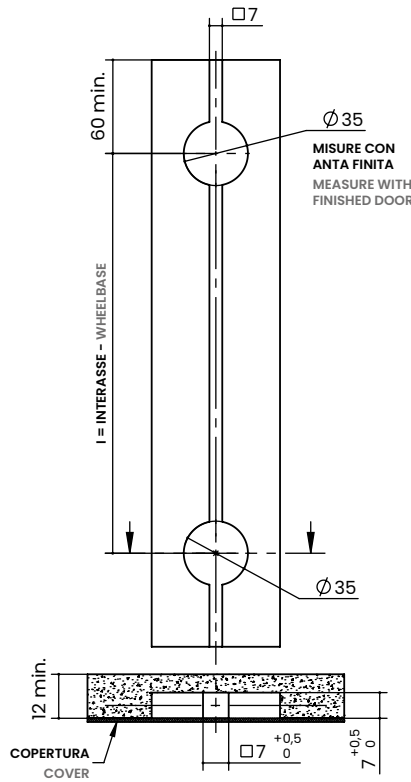
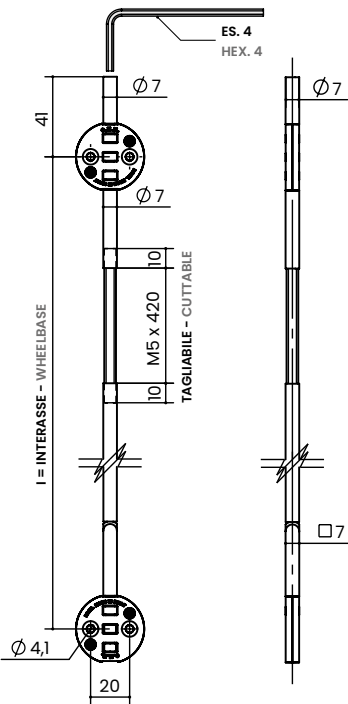
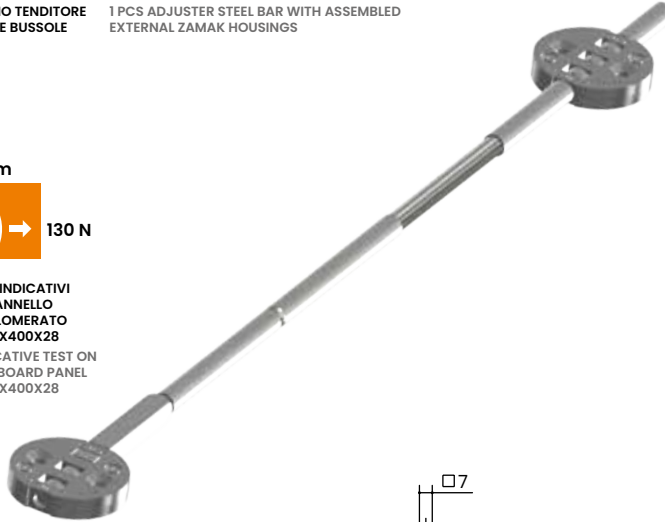

Normalmente utilizzati
su pannelli di legno
agglomerati assemblati
esternamente o in
tamburati di piccolo
spessore. Interasse
min. 1200, max. 2800.

PER MAGGIORI DETTAGLI TECNICI CONSULTARE
'INFORMAZIONI GENERALI' A FINE CAPITOLO 6.

Normally used on wooden
panels agglomerated
or hollow wood panels.
Recommended for
assembly under the covers
in wood veneer. Single
adjustment. Centre distance
min. 1200, max. 2800.

FOR MORE TECHNICAL DETAILS, PLEASE
REFER TO 'GENERAL INFORMATION' AT THE
END OF SECTION 6.

ACCESSORI ACCESSORIES



CHIAVE ES. 4
HEX. KEY 4
P.A087

Per maggiori informazioni
vedere sezione **10 ACCESSORI**

For further information see
section **10 ACCESSORIES**

TIPO TYPE	MISURA MEASURE	I INTERASSE WHEELBASE	FINITURA FINISHING	IMBALLO SU BANCALE PACKED ON PALLET KG / PZ	BOX 25 PZ KG / BOX	BOX 100 PZ KG / BOX
TN423.	1700.	1700	00 GREZZO RAW Minimo ordine 100 pz MOQ 100 pcs Misure a richiesta minimo ordine 300 pz Measure on request 300 pcs MO	0,57	14,2	57
	1900.	1900		0,62	15,5	62
	2010.	2010		0,65	16,2	65
	2300.	2300		0,73	18,2	73
	2450.	2450		0,77	19,3	77
	2610.	2610		0,82	20,5	82
	2760.	2760		0,86	21,6	86
	2800.	2800		0,87	21,8	87

Codice composto con i dati evidenziati in arancione | Code composed with data highlighted in orange | es. e.g. **TN423.2300.00**

SERIE TN500

TN500 SERIES

I tenditori della serie TN500 sono normalmente assemblati su pannelli di tamburato.

CARATTERISTICHE FONDAMENTALI:

- Regolazione singola e doppia.
- La regolazione singola è normalmente posta sulla parte superiore.

Regolazione singola ± 10 , doppia ± 20 ; interasse minimo 1200, massimo 2800.

TN400 series tensioners are normally assembled on hollow wood panels.

KEY FEATURES:

- Single and double adjustment.
- Single adjustment is normally placed on the top.

Adjustment: single ± 10 , double ± 20 ; centre distance: minimum 1200, maximum 2800.

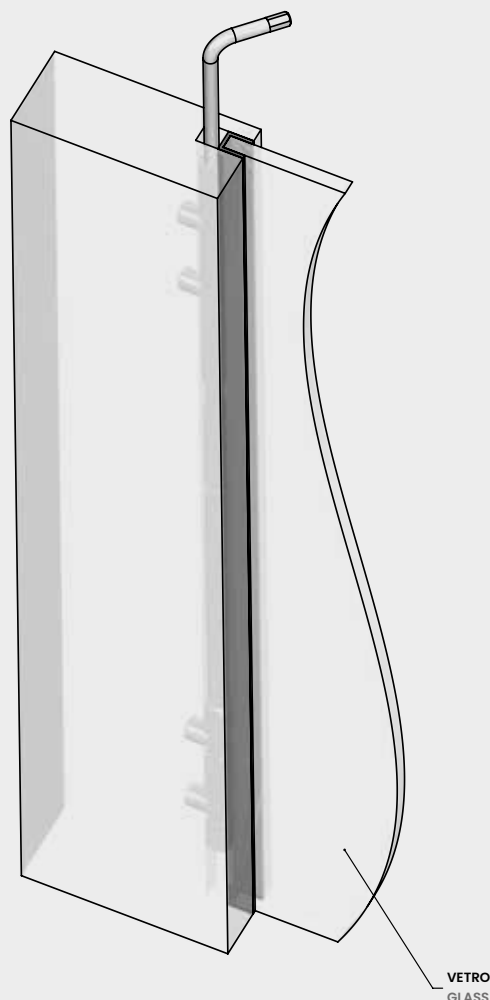

TN500

SCHEMA REGOLAZIONE TENDITORI

ADJUSTING SCHEME WARDROBE ADJUSTERS

Il tenditore lavora in entrambe le direzioni:

- girando la chiave in senso orario spinge in una direzione;
- girando la chiave in senso anti-orario spinge nell'altra direzione.

The tensioner works in both directions:

- turning the key clockwise pushes in one direction;
- turning the key anti-clockwise pushes in the other direction.

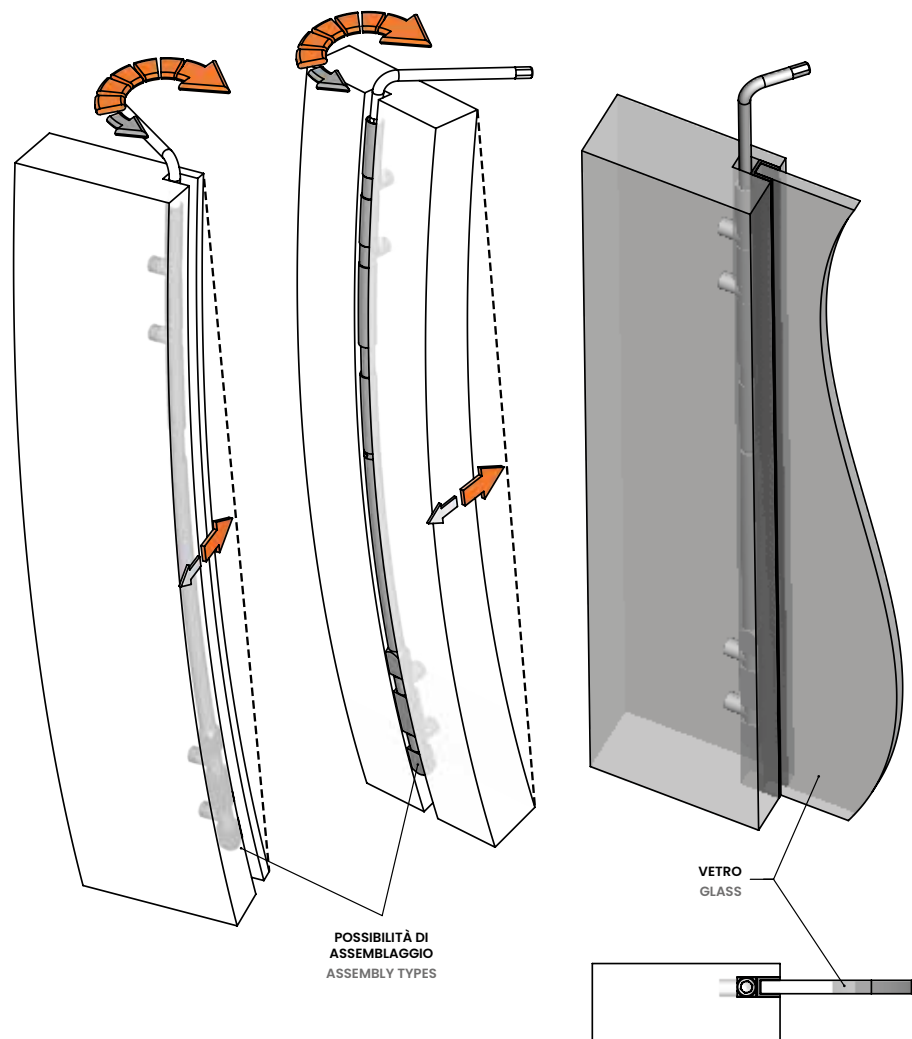

TN501

TENDITORE A SCOMPARSA HIDDEN WARDROBE ADJUSTER

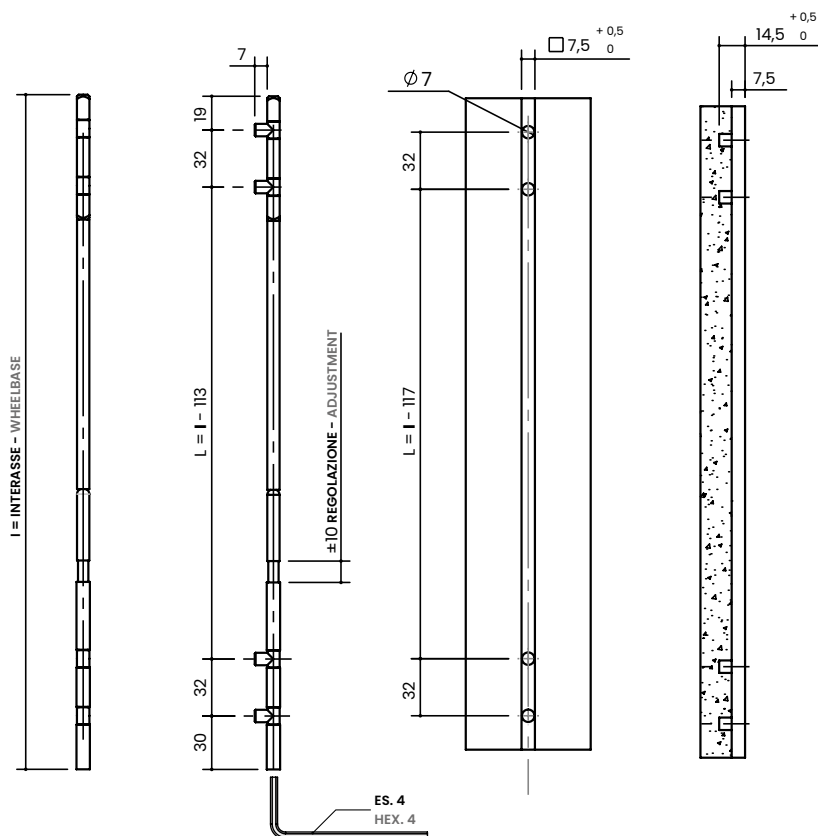
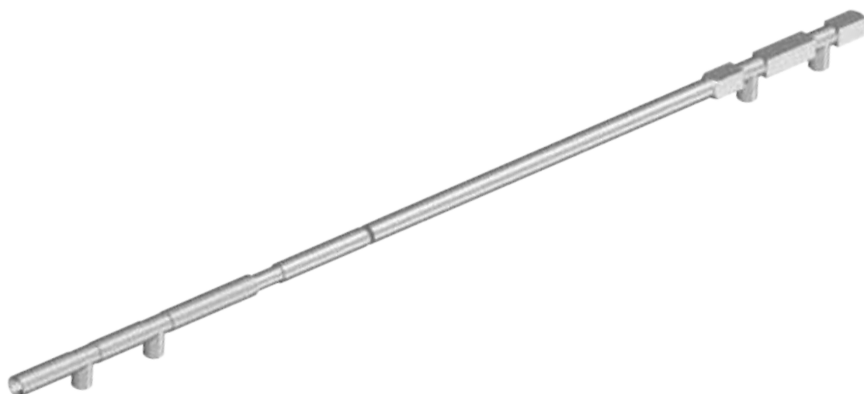

ACCIAIO
STEEL

Normalmente assemblati
su ante a telaio in legno.

Regolazione ± 10 ;
interasse min. 1200,
max. 2800.

PER MAGGIORI DETTAGLI TECNICI CONSULTARE
'INFORMAZIONI GENERALI' A FINE CAPITOLO 6.

In generally assembling
on wood doors.

Adjustment ± 10 ;
weelbase min. 1200,
max. 2800.

FOR MORE TECHNICAL DETAILS, PLEASE
REFER TO 'GENERAL INFORMATION' AT THE
END OF SECTION 6.

ACCESSORI ACCESSORIES

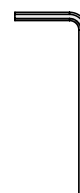

CHIAVE ES. 4
HEX. KEY 4
P.A087

Per maggiori informazioni
vedere sezione **10 ACCESSORI**

For further information see
section **10 ACCESSORIES**

TIPO TYPE	MISURA MEASURE	I INTERASSE WHEELBASE	FINITURA FINISHING	PZ / BOX	KG / BOX
TN501.	1845.	1845	00 GREZZO RAW	25	6,3
	2145.	2145		25	15,3
	2300.	2300		25	16,5
	2435.	2435		25	17,5
	2585.	2585		25	18,5
	2745.	2745		25	19,7
	2895.	2897		25	20,6

Codice composto con i dati evidenziati in arancione | Code composed with data highlighted in orange | es. e.g. **TN501.2435.00**



Contacts

OMM srl **dell'Ing. Roberto Natale Mariani**

Via Lavoratori Autobianchi 1 | lotto 13/I
20832 | Desio - MB | Italy

P. Iva | CF 02048560961

N. Registro Imprese 02048560961

CENTRALINO **CONTACT CENTER**

+39 0362 622377

ORDINI E CONSEGNE **ORDERS AND DELIVERIES**

ordini.italia@omm.name - ordini italia
export@omm.name - foreign orders

UFFICIO TECNICO **TECHNICAL DPT**

ufficiotecnico@omm.name

AMMINISTRAZIONE **ADMINISTRATION**

omm@omm.name

WWW.OMM.NAME

